

***Intermolecular interactions:  
3D computer simulations and  
SPR biosensor analysis***

***Alexis S. Ivanov***

***Institute of Biomedical Chemistry RAMS, Moscow, Russia***

***Russian State Medical University, Moscow, Russia***

# Introduction

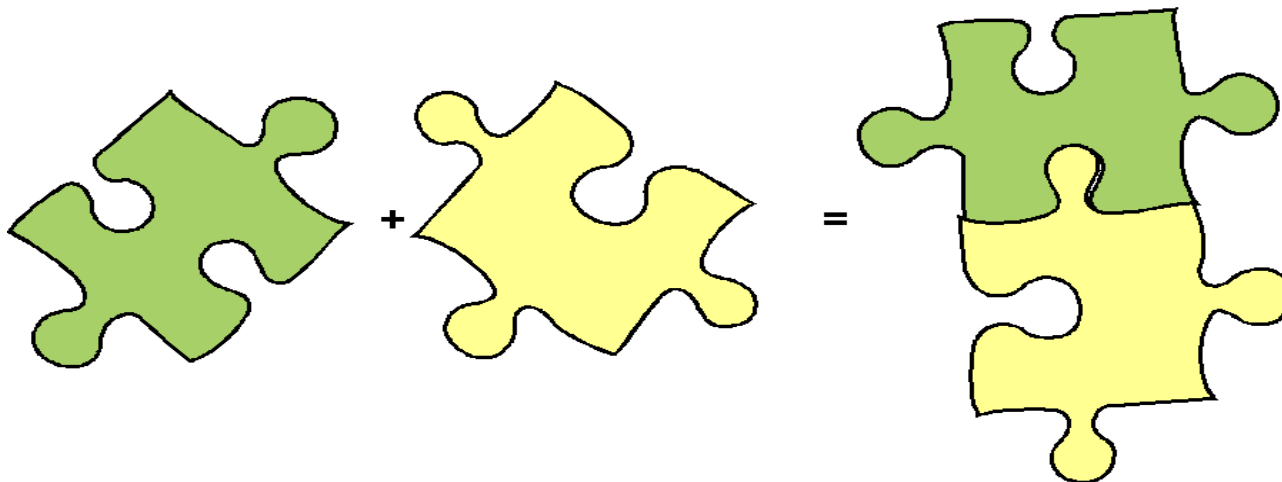
---

- ***All biological processes are mediated by different types of intermolecular interaction in living organisms***
- ***Therefore virtual and experimental researches of intermolecular interactions are the fundamental task of modern system biology***
- ***The main destination of this lecture is a short overview of two complementary approaches :***
  - ***In silico - computer 3D simulation of molecular complexes;***
  - ***In vitro - experimental analysis of molecular interactions by using the optical biosensor utilized the effect of surface plasmon resonance (SPR)***

# *In silico approach*

---

- ***Molecular Docking - computer 3D simulation of complexes of two or more molecules by their joining***
- ***Two main functions of Docking procedure:***
  - 1) *Generation of hypothesis about complexes of molecules with their positions and conformations*
  - 2) *Scoring and selection hypothesis of molecular complexes*

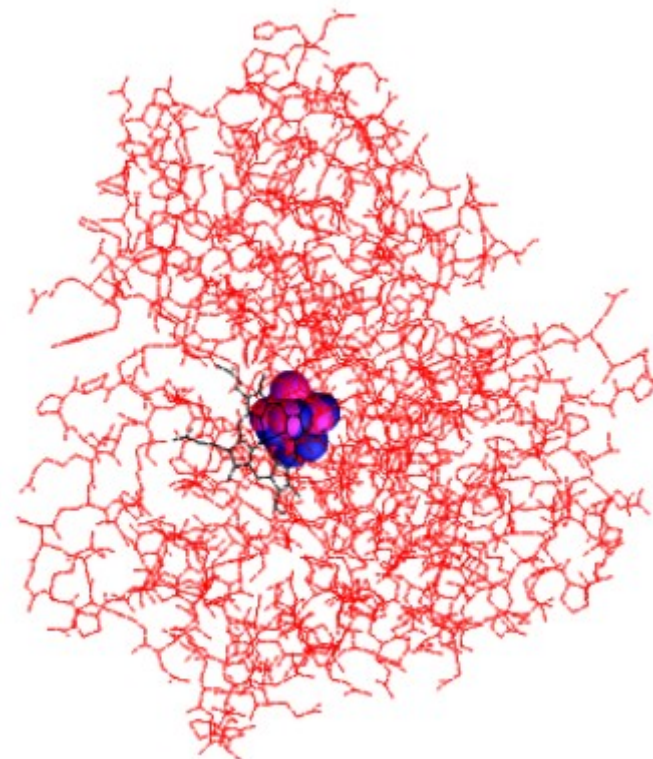


# Molecular Docking

- *The simplest version - pair docking of two molecules*
- ***NOTICE: Method does not give any information on molecules movement during complex formation***
  - ➔ *Docking procedure gives only hypothesis about final state of molecular complex*
  - ➔ *So, you can obtain hypothesis about complex of target protein with ligand inside*

**For example:**

***Cytochrome P450cam with camphor in closed active site***



# Molecular docking

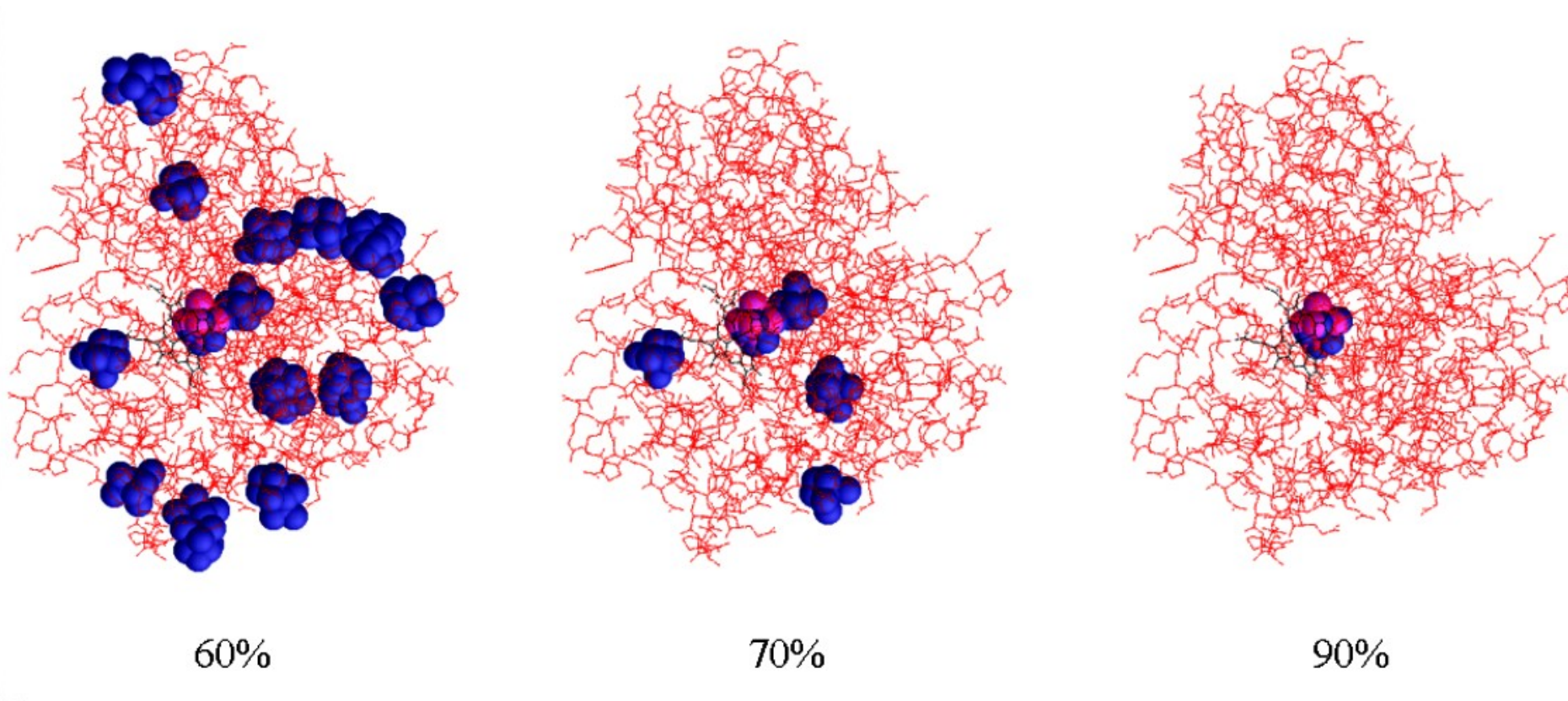
---

- **Docking software generates a lot of primary hypothesis of molecular complexes**
  - **NOTICE: Docking procedure does not give single true version of molecular complex**
- **There are various algorithms of hypotheses generation of molecular complexes:**
  - **Total search**
  - **Monte Carlo search**
  - **Genetic algorithm**
  - **etc.**

# Molecular docking applications

- 1) **3D modeling of any types of molecular complexes**
  - Protein-protein; Protein-ligand; Protein-DNA(RNA); etc.
- 2) **Analysis of molecules contact interfaces in complexes**
- 3) **Ligands binding site searching and analysis**

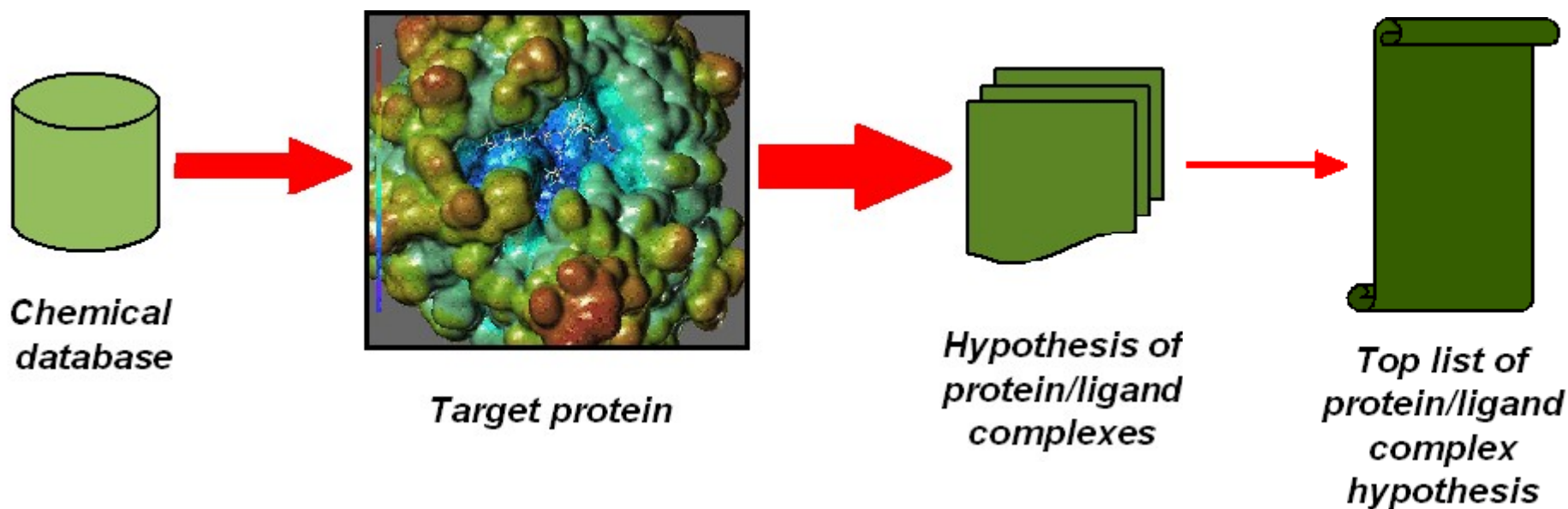
**For example:** Cytochrome P450cam - camphor binding site searching



# Molecular docking applications

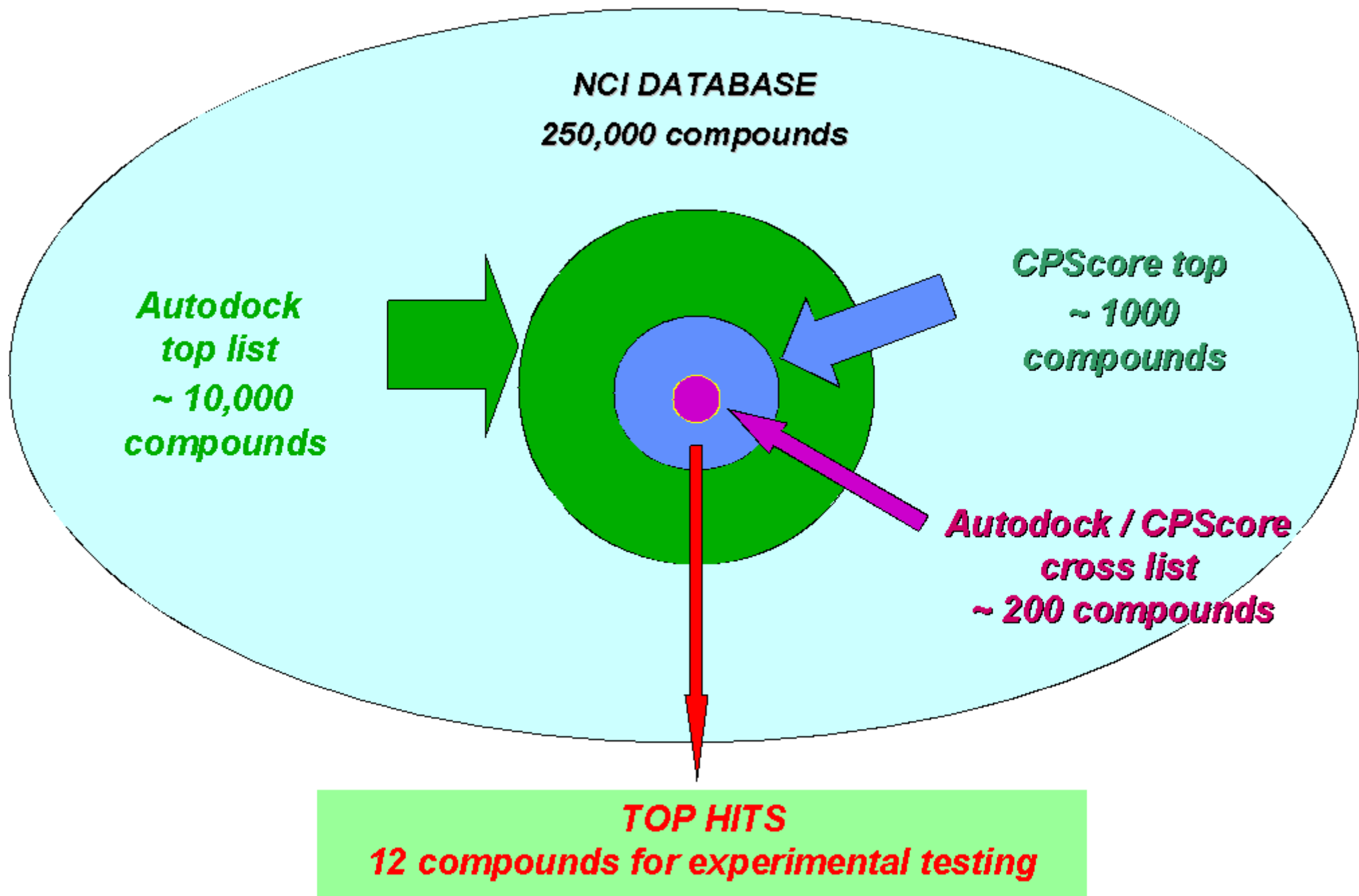
## 4) *Virtual screening of lead compounds for target protein*

- *Sequential hypothesis generation of complexes between target protein and all compounds from chemical database*
- *Scoring and selection of most favorable complexes*



For example:

**Virtual screening of potential inhibitors of HIV protease dimerization**

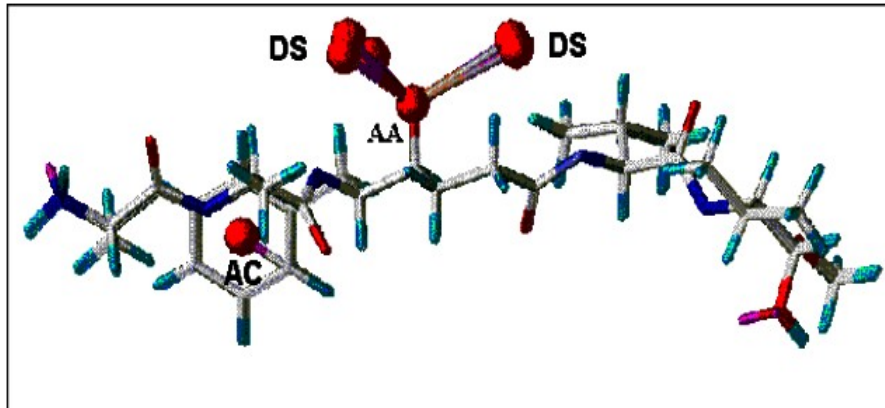




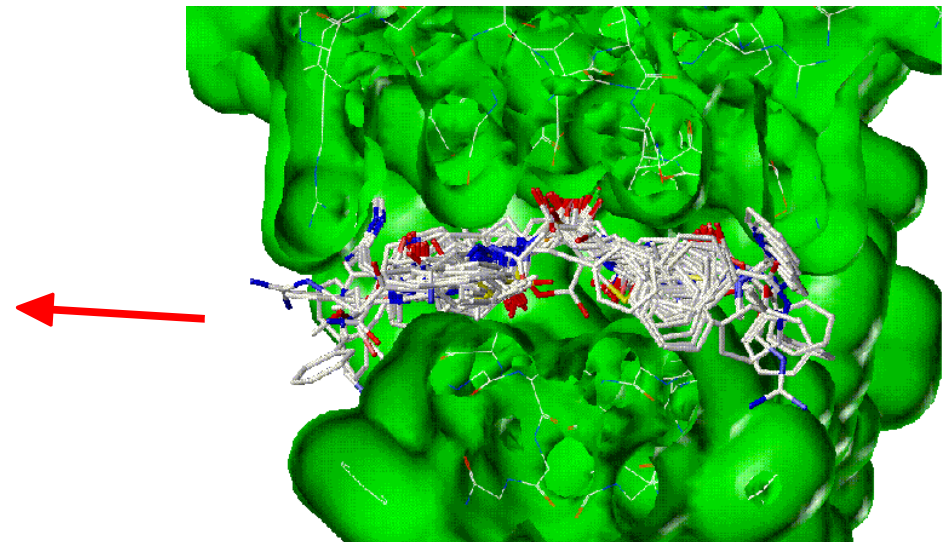
# Molecular docking applications

## 5) Space overlapping of ligands (structural alignment) in binding site of target protein

→ Pharmacophore analysis



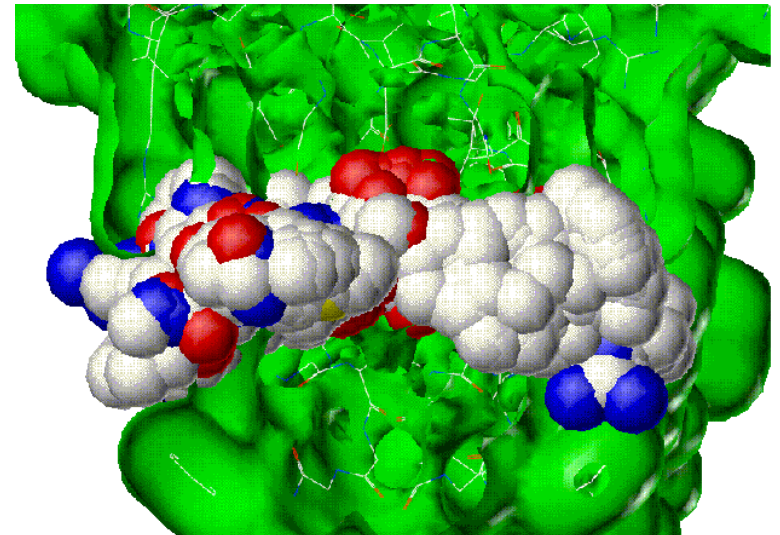
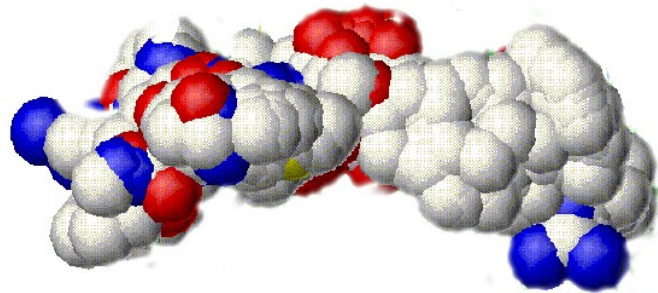
AA - acceptor atom  
DS - donor site  
AC - aromatic ring centroid



# Molecular docking applications

## 5) Space overlapping of ligands (structural alignment) in binding site of target protein

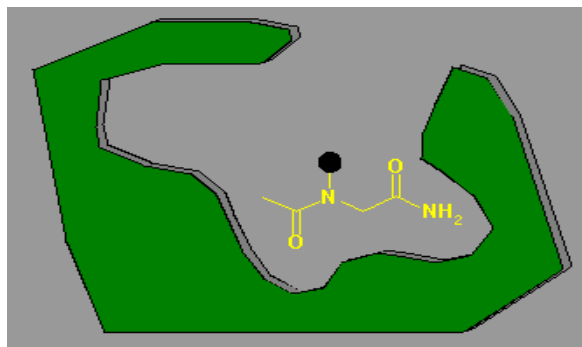
- Pharmacophore analysis
- Binding site mould generation



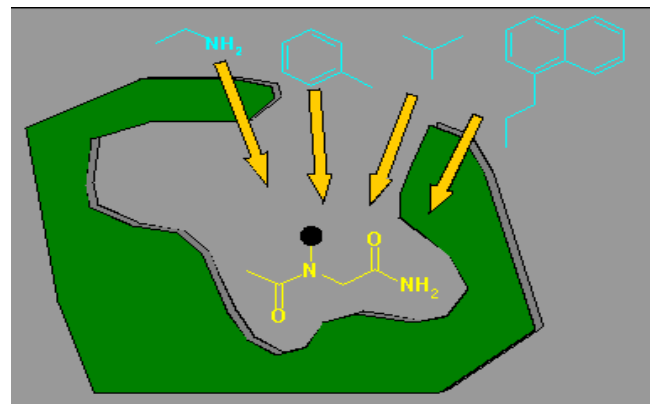
# Molecular docking applications

- **Molecular fragments docking**

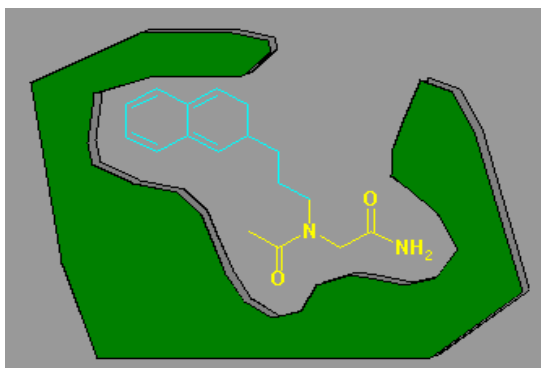
- ➔ *De novo design*
- ➔ *Lead compounds modification*



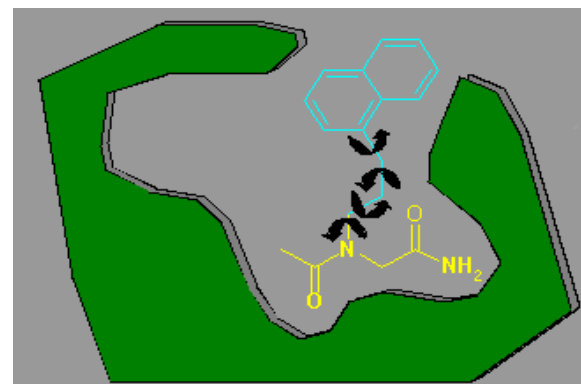
*Docking of lead fragment*



*Substitution of side group*



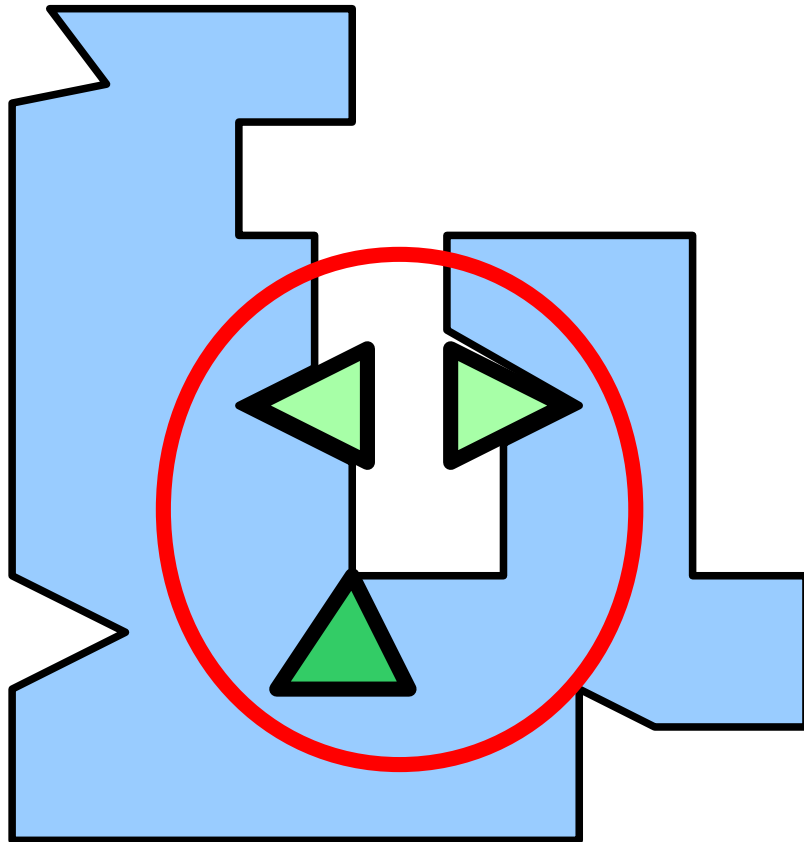
*Final hypothesis*



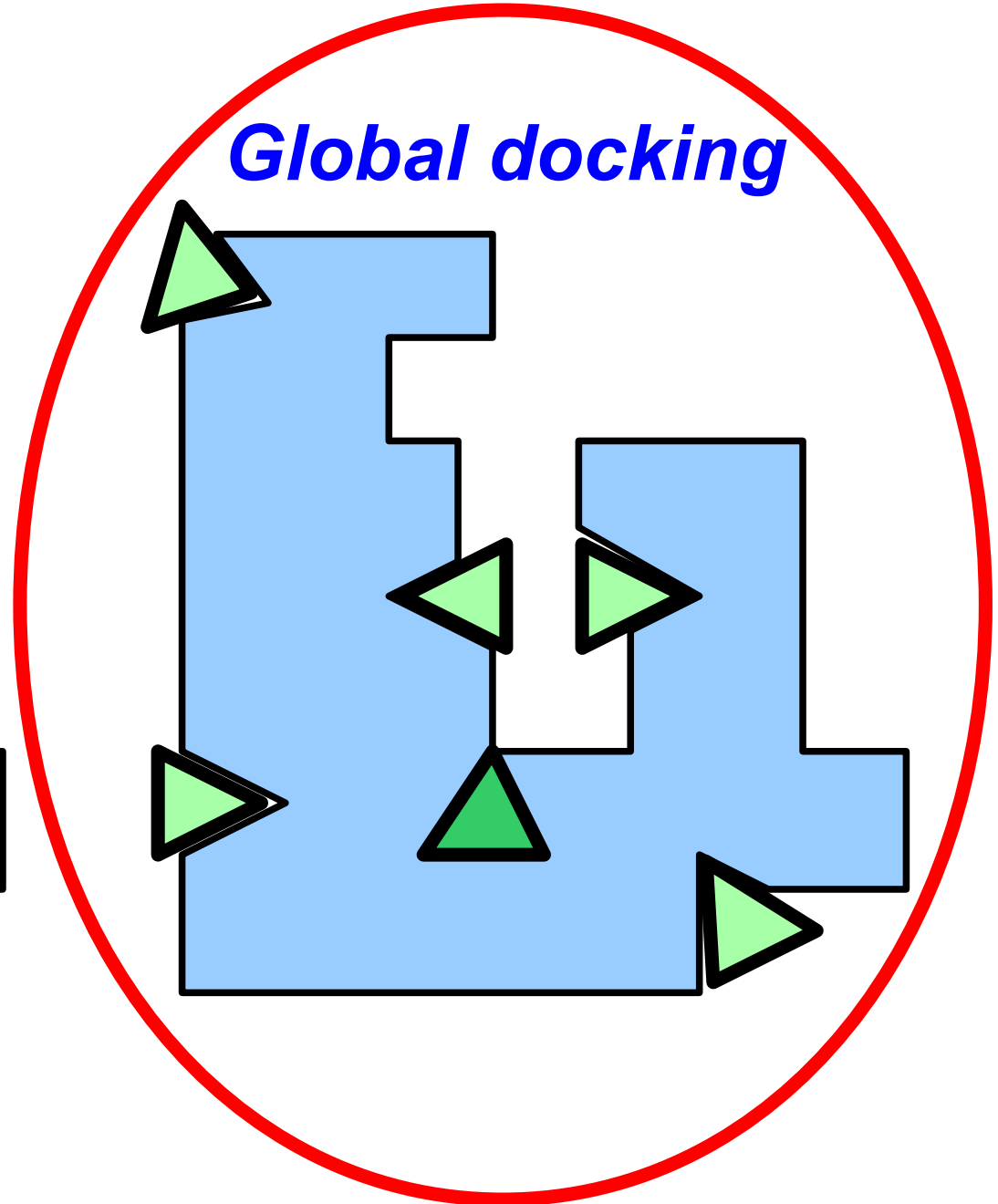
*Model optimization*

# Two variants of docking

*Local docking*



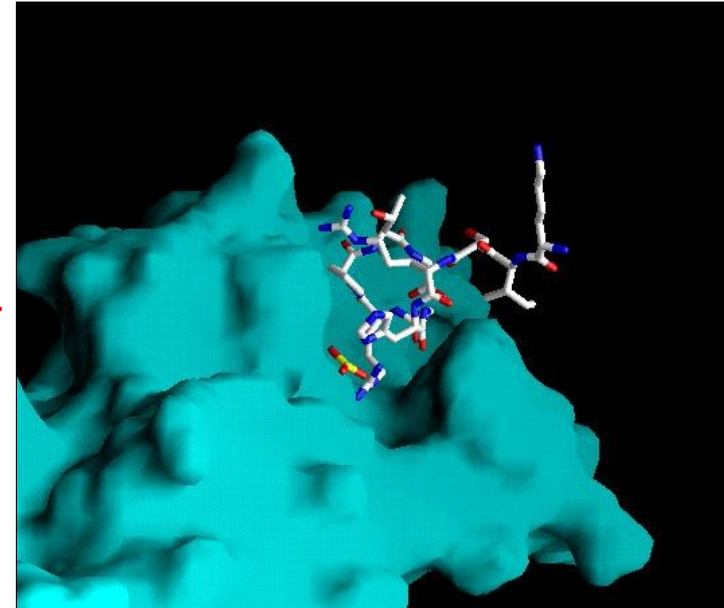
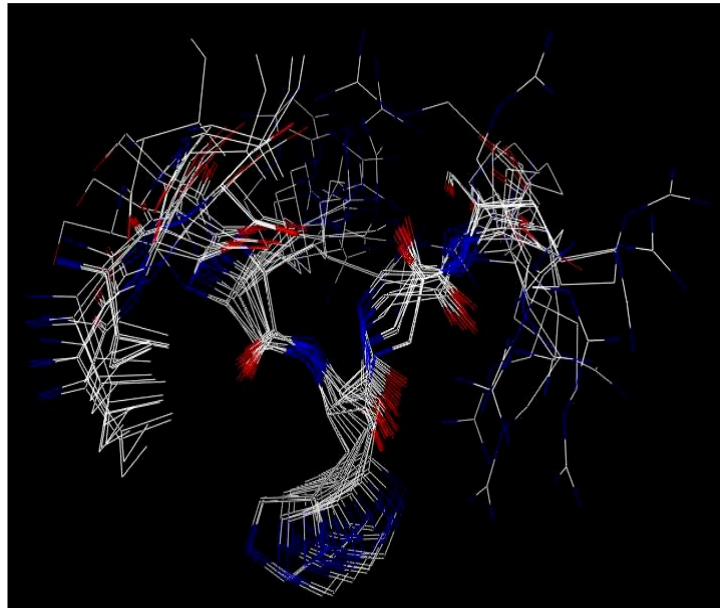
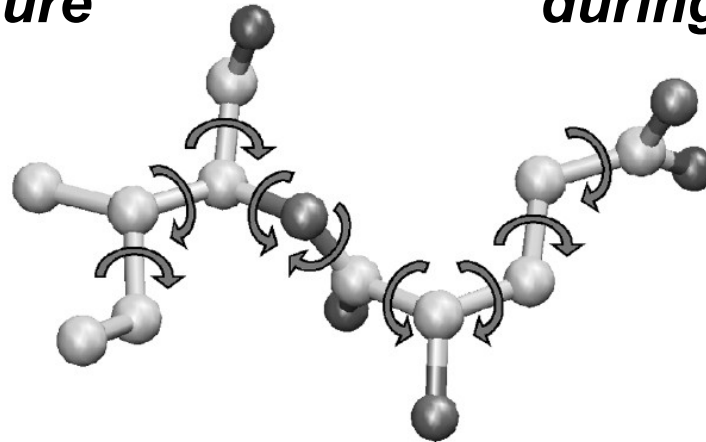
*Global docking*



# Docking of conformational flexible molecules

**1) Probable ligands conformation are generated before docking procedure and enlarge database as separate molecules**

**2) Probable ligands conformation are generated during docking procedure (flexible docking)**



# Some examples of docking software

---

- **DOCK**

- <http://www.cmpharm.ucsf.edu/kuntz/dock.html>

- **Algorithm of molecular shape matching**  
**< v. 3.5 – rigid docking, > v. 4.0 – ligand flexible docking.**  
**Software is adopted for ligands database mining**

- **GOLD**

- <http://www.ccdc.cam.ac.uk/>

- **Genetic algorithm, ligand flexible docking**

- **FLEXX**

- <http://www.tripos.com>

- **Ligand flexible docking + flexible conformation of amino acids side chains**

- **FRED**

- <http://www.openeye.com>

- **Rigid docking + ligand conformers generation and selection.**  
**Very fast algorithm**

- **AUTODOCK**

- <http://www.scripps.edu/pub/olson-web/doc/autodock/>

- **Genetic algorithm, ligand flexible docking**

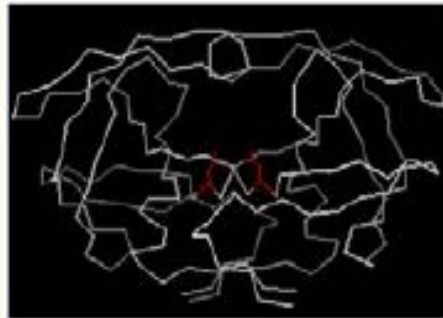
- **LIGANDFIT**

- <http://www.accelrys.com/cerius2/c2ligandfit.html>

## 1, 2

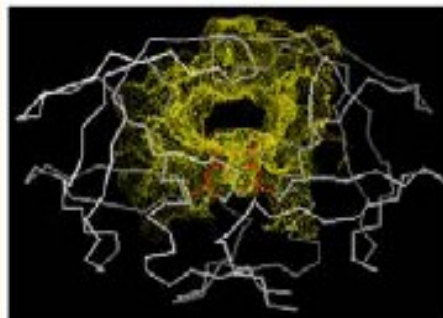
### HOW DOCK WORKS

Step 1: Start with crystal coordinates of target receptor



In this example, HIV-1 protease is the target receptor, with its active site aspartyl groups identified in red.

Step 2: Generate molecular surface for receptor

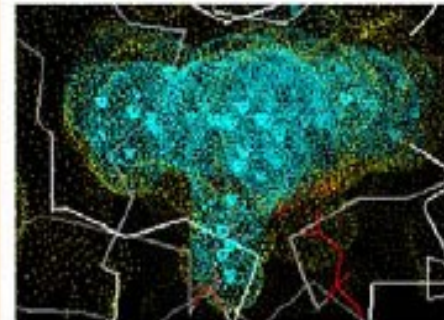


This is performed using Mike Connolly's ms program. Note that only the surface for the active site needs to be generated.

For the rest of this overview, we'll use a blow up of the active site.

## 3

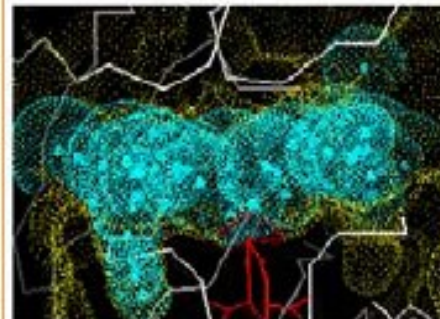
Step 3: Generate spheres to fill the active site



The shape of cavities in the receptor is used to define spheres; the centers of the spheres become potential locations for ligand atoms.

In the following picture, the sphere centers are identified by cyan triangles, and the sphere surfaces are shown.

Side view of spheres:



Step 4: Matching

Sphere centers are then matched to the ligand atoms, to determine possible orientations for the ligand. Typically on the order of tens of thousands of orientations are generated for each ligand molecule.

## 4, 5

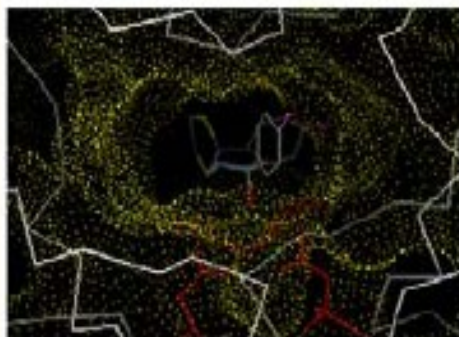
### Step 4: Matching

Sphere centers are then matched to the ligand atoms, to determine possible orientations for the ligand. Typically on the order of tens of thousands of orientations are generated for each ligand molecule.

### Step 5: Scoring

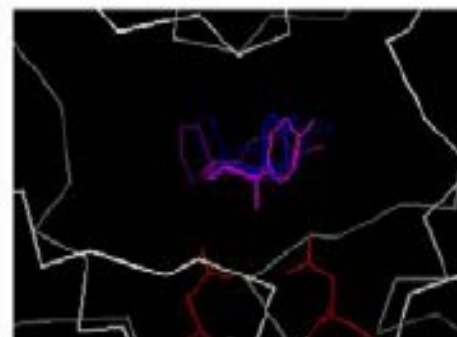
Each oriented molecule is then scored for fit. There are currently 3 scoring schemes:

- **Shape scoring**, which uses a loose approximation to the Lennard-Jones potential
- **Electrostatic scoring**, which uses the program DELPHI to calculate electrostatic potential
- **Force field scoring**, which uses the AMBER potential.



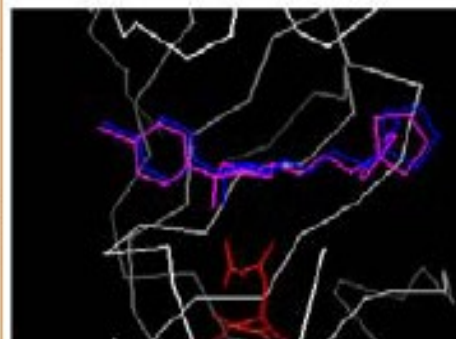
This is the top-scoring orientation for the molecule thiokeetal in the HIV-1-protease active site, using force-field scoring. *(Please note that this is a different orientation than previously published. Earlier runs were done using the shape scoring scheme, and a different version of the protease crystal structure)*

### Final notes:



Here is a comparison of the top scoring orientation of the molecule thiokeetal with the orientation found in the crystal structure.

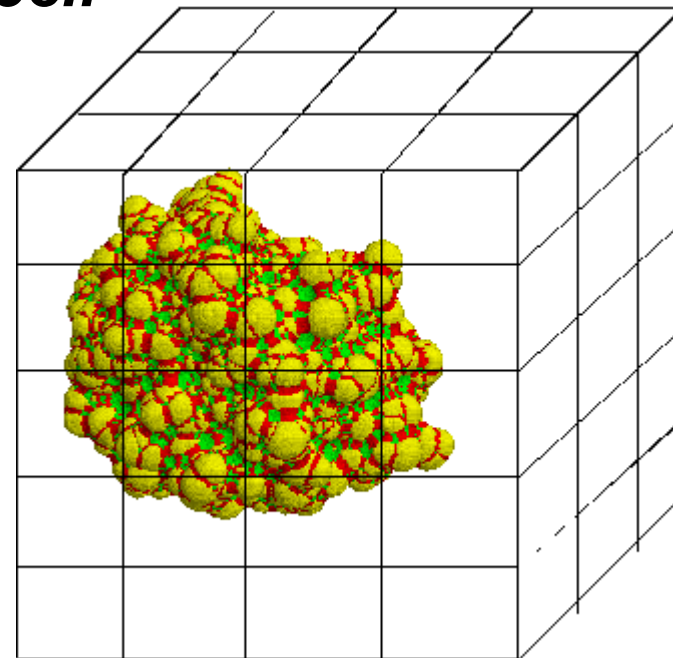
Rotating the view 90 degrees...





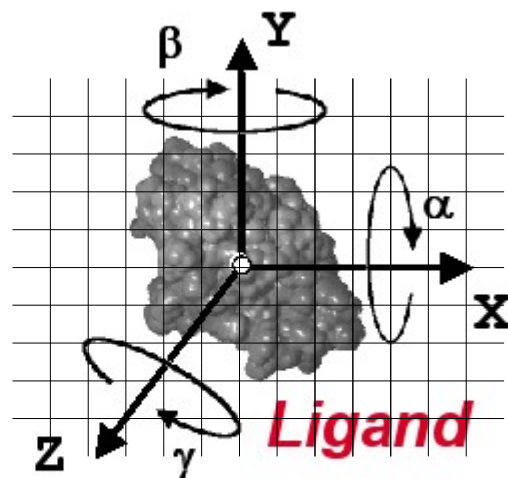
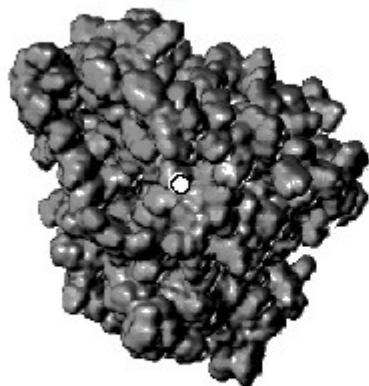
# ***Lattice approximation in molecular docking***

- ***Position and orientation of one molecule (named target) are fixed***
  - ***While positions and orientation of other molecule (named ligand) are discretely changing***
- ***Ligand's weight center can have coordinates only of lattice nodes and precision of ligand positioning depends on the value of lattice cell***
- ***Ligand can rotated about x-y-z axis only with prescribed angle increment***



# DockSearch

**Target**



**Target** molecule is fixed in space, while **ligand** molecule is displaced by lattice nodes and rotated about x-y-z axis with angle increment



1, 2 - negative hypothesis

3-6 - positive hypothesis

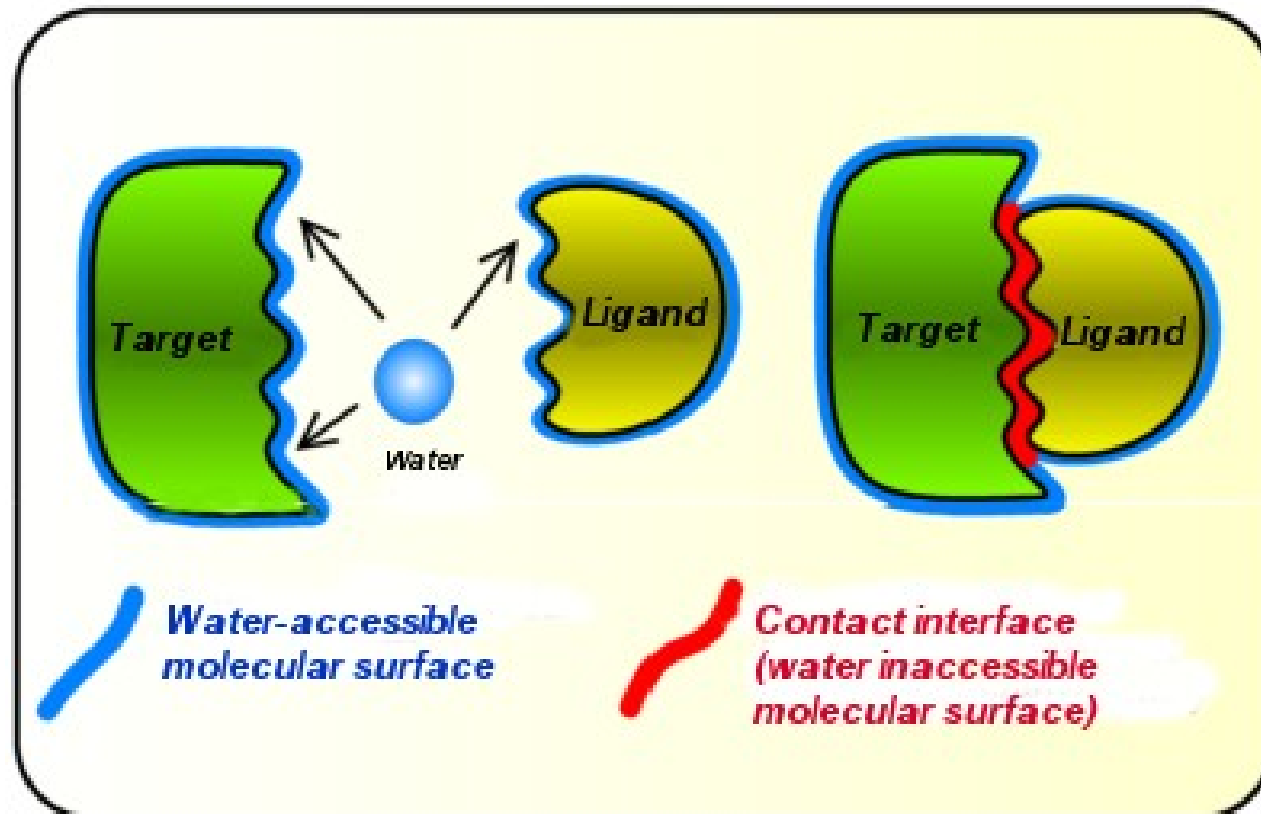
4-6 - cluster of hypothesis

# Analysis of contact interface area

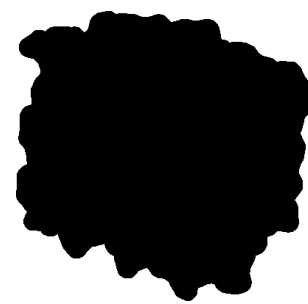
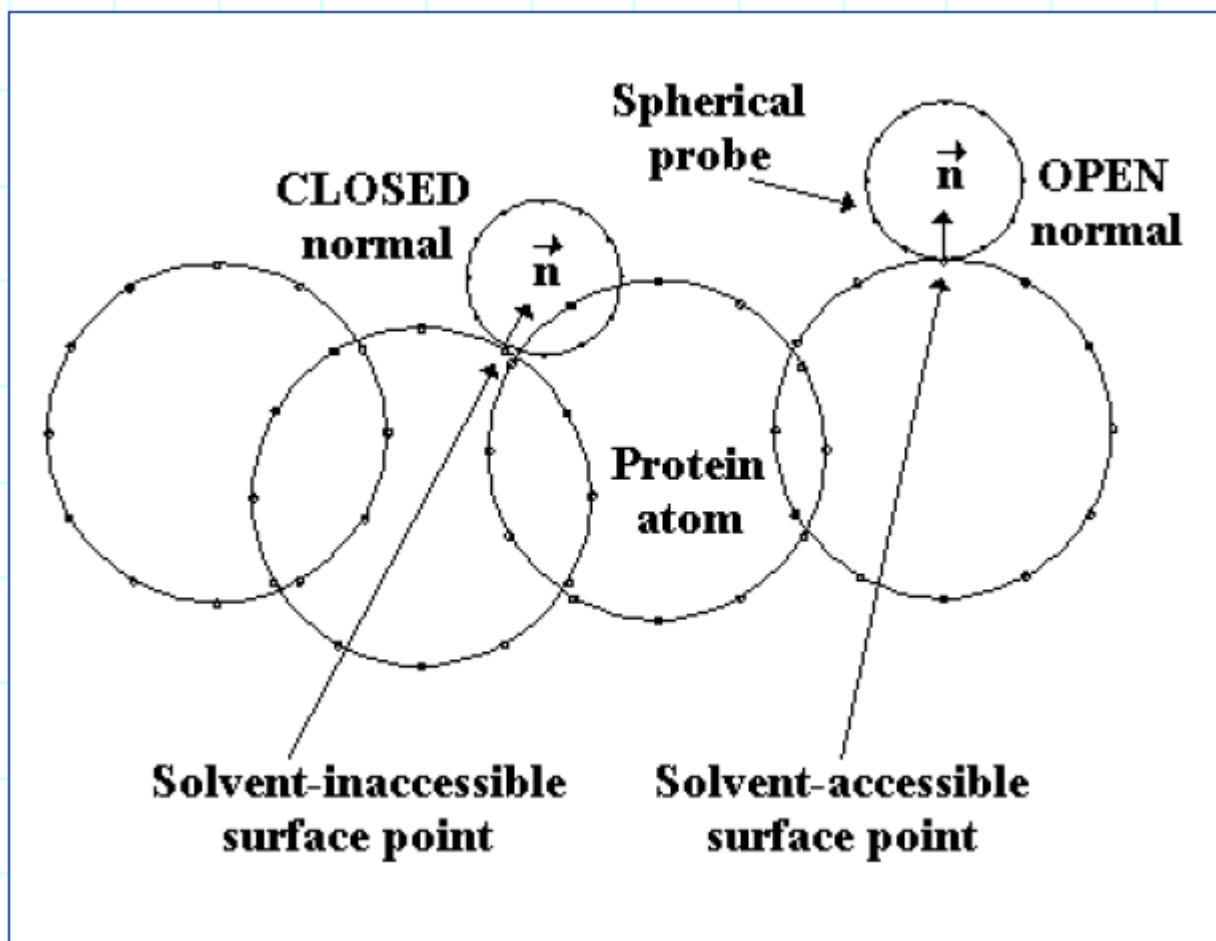
- Calculation of solvent accessible surfaces of free receptor, free ligand and their complex

$$S_{\text{contact}} = S_{\text{target}} + S_{\text{ligand}} - S_{\text{complex}}$$

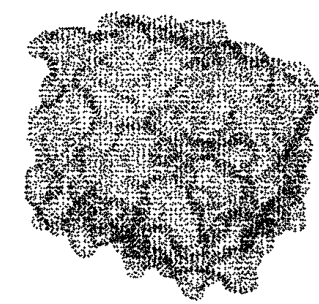
- Checking for inter-molecule penetrations and score the amount of contacts



# DockSearch



*VDW surface*



*642 dots/atom*



*162 dots/atom*



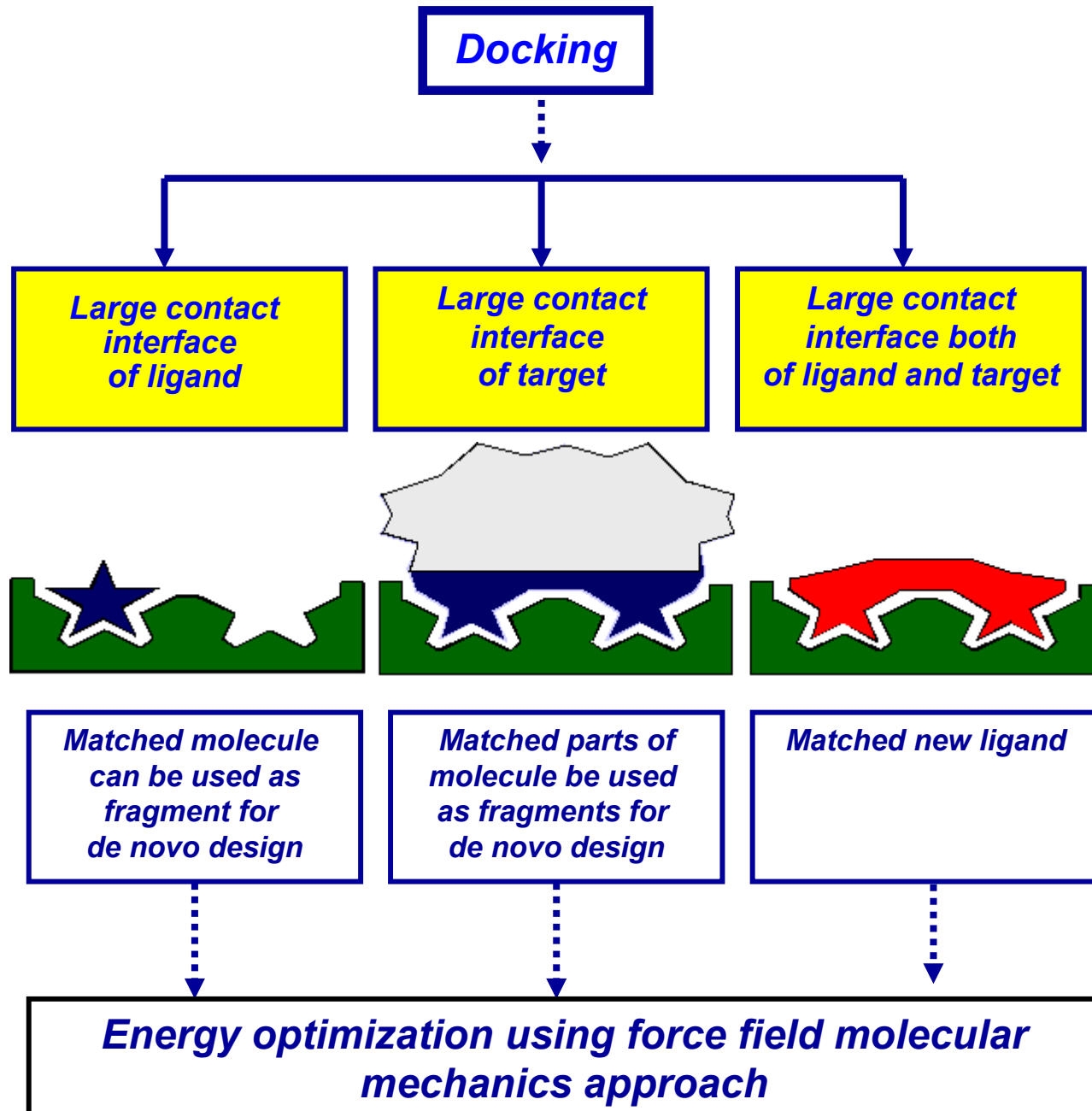
*42 dots/atom*

# Scoring and selection of docking hypothesis

- **Ranking hypothesis of complexes by geometrical score and enthalpy part ( $\Delta H$ ) of free energies change ( $\Delta E$ )**
- **Unfortunately, entropy part ( $T \cdot \Delta S$ ) of  $\Delta E$  can not be calculated by molecular mechanics approach with using force fields**
  - ➔ **Loss of some degrees of freedom in target and ligand conformations**
  - ➔ **Loss of 3 rotation and 3 displacement degrees of freedom**
  - ➔ **Hydrophobic interactions**

$$\Delta G = \Delta H - T \cdot \Delta S = -RT \cdot \ln K_d$$

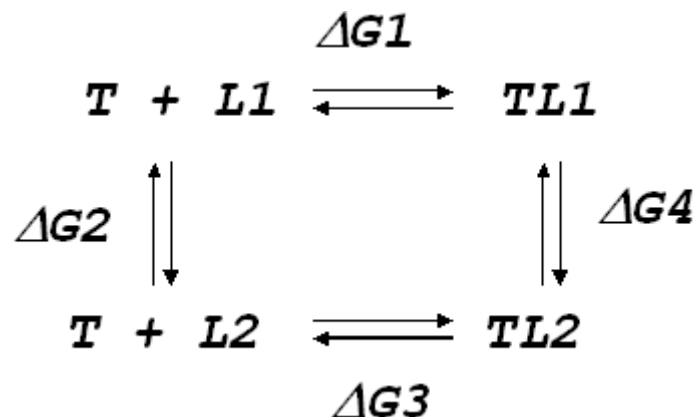
# Shape scoring of docking hypothesis



# Other functions for scoring docking hypothesis

- **Prediction values of  $K_d$ ,  $K_i$ ,  $IC_{50}$ , ...**

- **Correlation equations**
- **Neuron nets**
- **Free energy perturbation**



$\Delta G1$  – know from experiment

$\Delta G2$  – can be calculated from modeling  
 $L1 \rightarrow L2$  in water

$\Delta G4$  – can be calculated from modeling  
 $L1 \rightarrow L2$  in complex with T

$$\Delta G1 - \Delta G3 = \Delta G2 - \Delta G4$$

or

$$\Delta G3 = \Delta G1 + \Delta G4 - \Delta G2$$

## **NOTICE:**

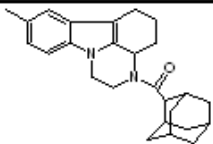
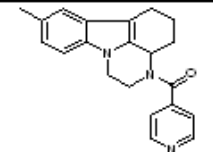
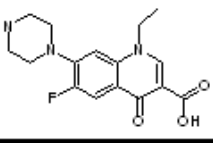
**This approach requires many cycles of molecular dynamics simulation (~100 ps per cycle) and demands powerful computational resources**

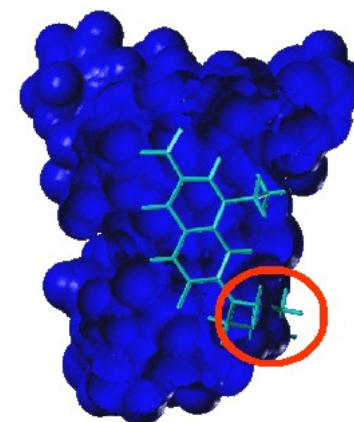
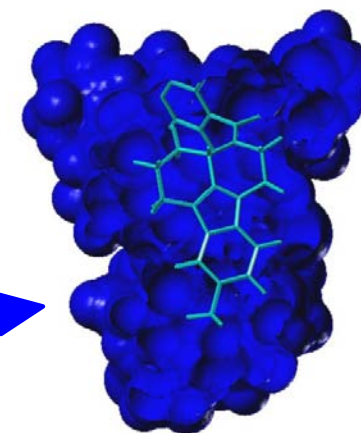
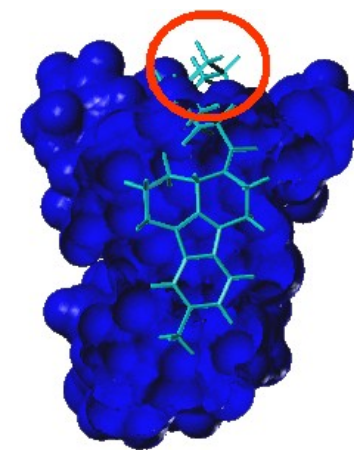
# Other functions for scoring docking hypothesis

- **Indirect methods**

- ➔ **Scoring based on pharmacophore model**
- ➔ **3D-QSAR + CoMFA (CoMSIA) models**
- ➔ **Comparison of ligand position with mould of binding site**

**IC<sub>50</sub> for  
ligands of  
MAO-A**

	Structure	Pred	Exp
1		0,26	>100
2		0,3	8,9
3		0,006	>1000





# *In vitro approach*

---

*Experimental analysis of molecular interactions by using the SPR biosensors*



*Biacore 3000*



*Biacore T100*

---

# ***What is SPR?***

# Phenomenon of changing color of glass, containing gold nanoparticles



*Licurg bowl, IV century (British museum)*



*Stained-glass window "Labors of the Months"  
Norwich, England, ~ 1480*

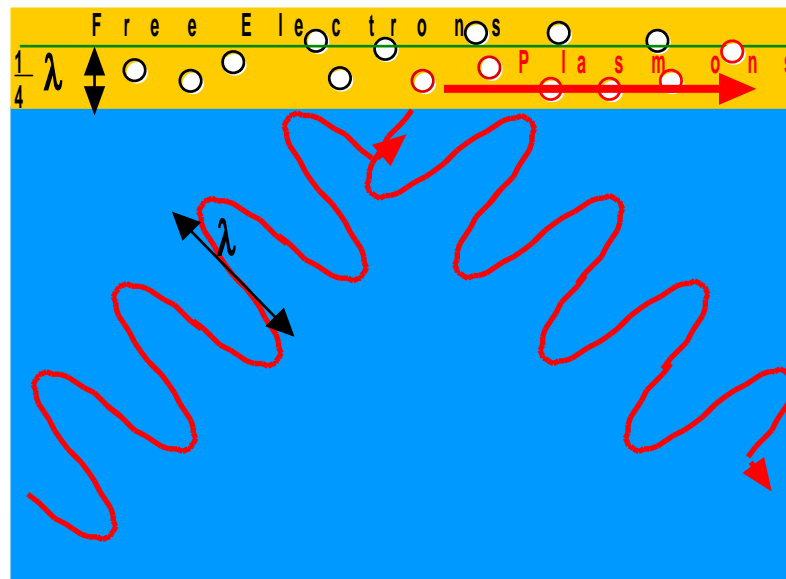
## Glass color

reflection – green  
look-through – red

- *This phenomenon was explained by effect of Surface Plasmon Resonance (SPR) discovered only in 1960*
- *In modern science this effect is refer to area of Quantum Nano-Optics*

# SPR

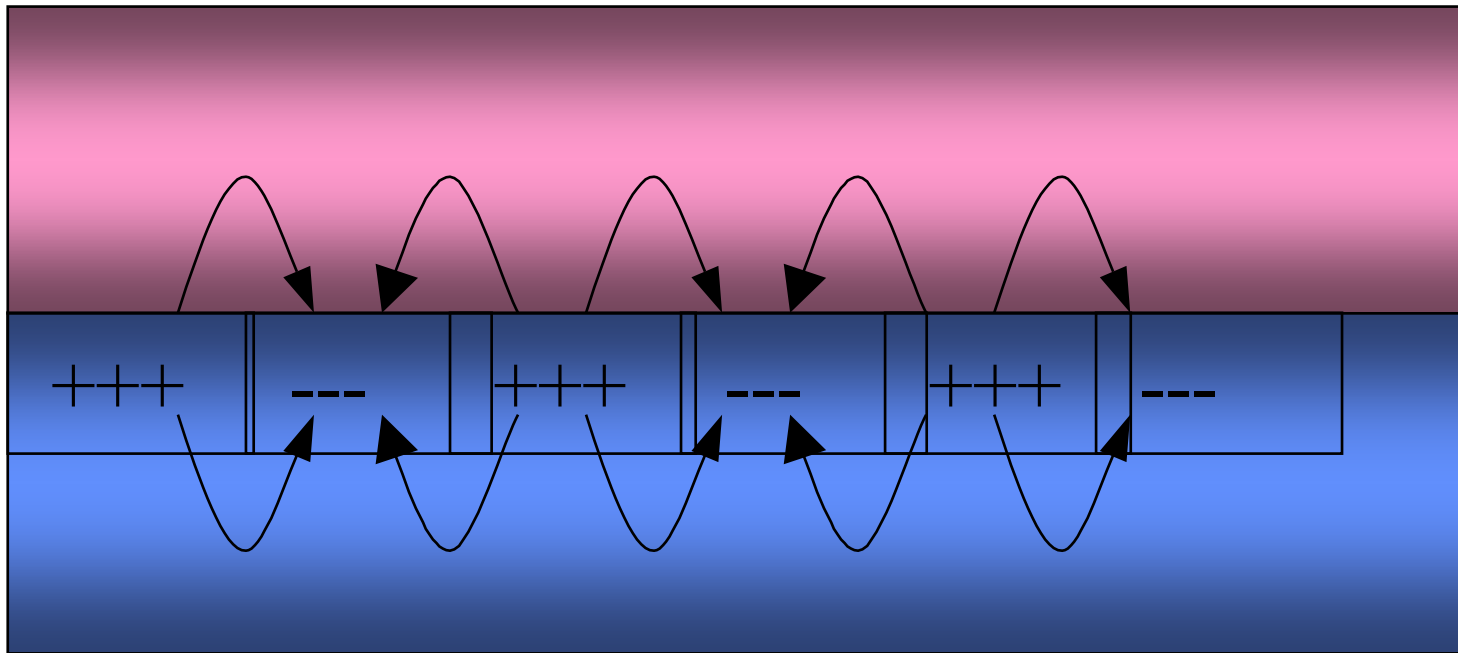
- **Reflecting surface is covered by thin layer of gold**
- **Photons can interact with free electrons in gold and at resonance conditions they transform into plasmon (quantum electromagnetic waves)**
- **Light in this case does not reflect**



# Surface Plasmon definition

***Plasmon - quantum collective electron oscillation at the surface of metal, expressed in occurrence of charge density fluctuation***

*Optical Properties of Solids,  
Fredrick Wooten, 1972 Academic Press*



***Electromagnetic field of plasmon reaches medium beyond the gold layer***

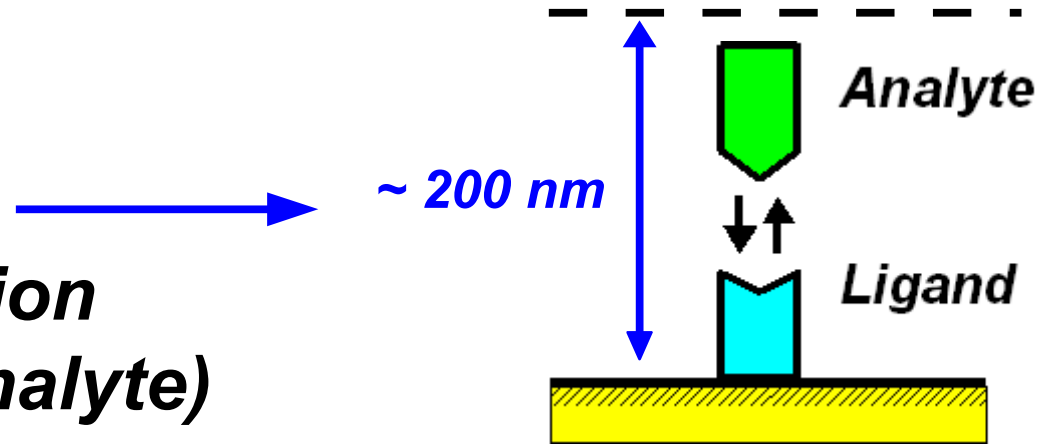
# Using SPR for registration of intermolecular interaction

---

- **Plasmon mobility (and therefore the value of resonance angle) depends on plasmon electromagnetic field coupling with medium beyond the gold mirror**
- **So, using SPR we can sense the “world behind the looking-glass”!**
- **The value of resonance angle is proportional to refractive index in a thin layer of medium beyond the gold (~ 300 nm)**
- **Using SPR technology you can trace in real time the mass transfer of any compounds between free medium and this layer**

# Using SPR for registration of intermolecular interaction

- ***If one type of interacting molecules (Ligand) is attached on the gold surface in SPR controlling area, you can see the interaction of second molecules (Analyte) with immobilized ligand by mass transfer of Analyte in both directions (molecular complex formation and dissociation)***



# SPR registration of intermolecular interaction

- **Real time registration:**

- kinetic curves of binding and dissociation - sensograms

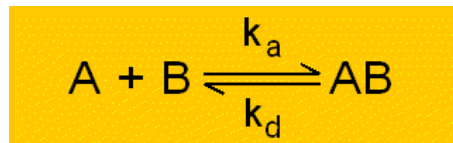
- **Mathematical analysis of sensograms:**

- association rate constant ( $k_a$ )

- dissociation rate constant ( $k_d$ )

- complex dissociation constant

$$K_D = k_a / k_d$$



- **Mathematical analysis of sensograms set obtained at different temperature:**

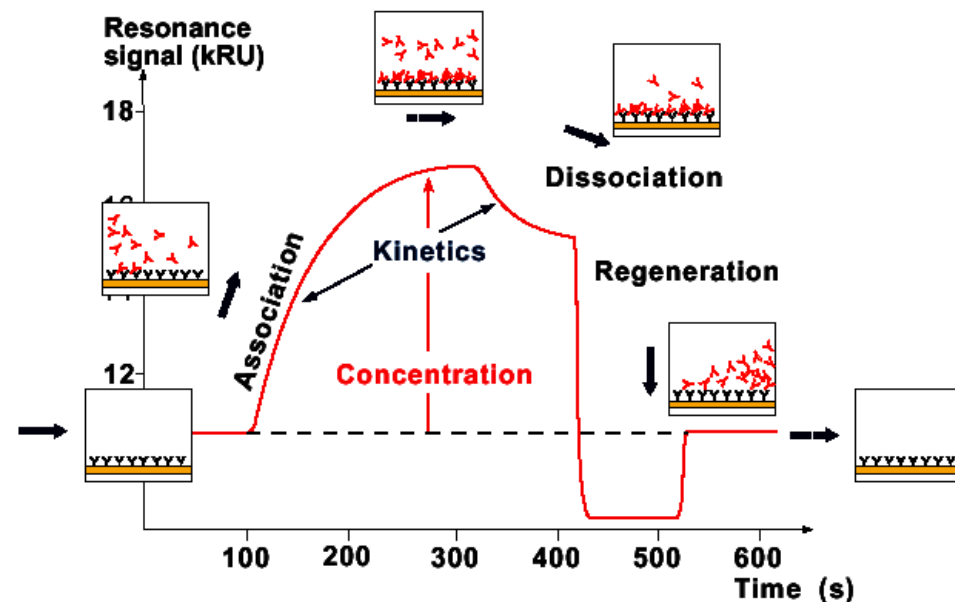
- Thermodynamics data:

- Free energy change

- Entropy change

- Enthalpy change

$$\Delta G = \Delta H - T \cdot \Delta S$$



» Association rate:  $\frac{d[AB]}{dt} = k_a \cdot [A] \cdot [B]$

» Dissociation rate:  $-\frac{d[AB]}{dt} = k_d \cdot [AB]$

» At equilibrium: Association = Dissociation

$$k_a \cdot [A] \cdot [B] = k_d \cdot [AB]$$

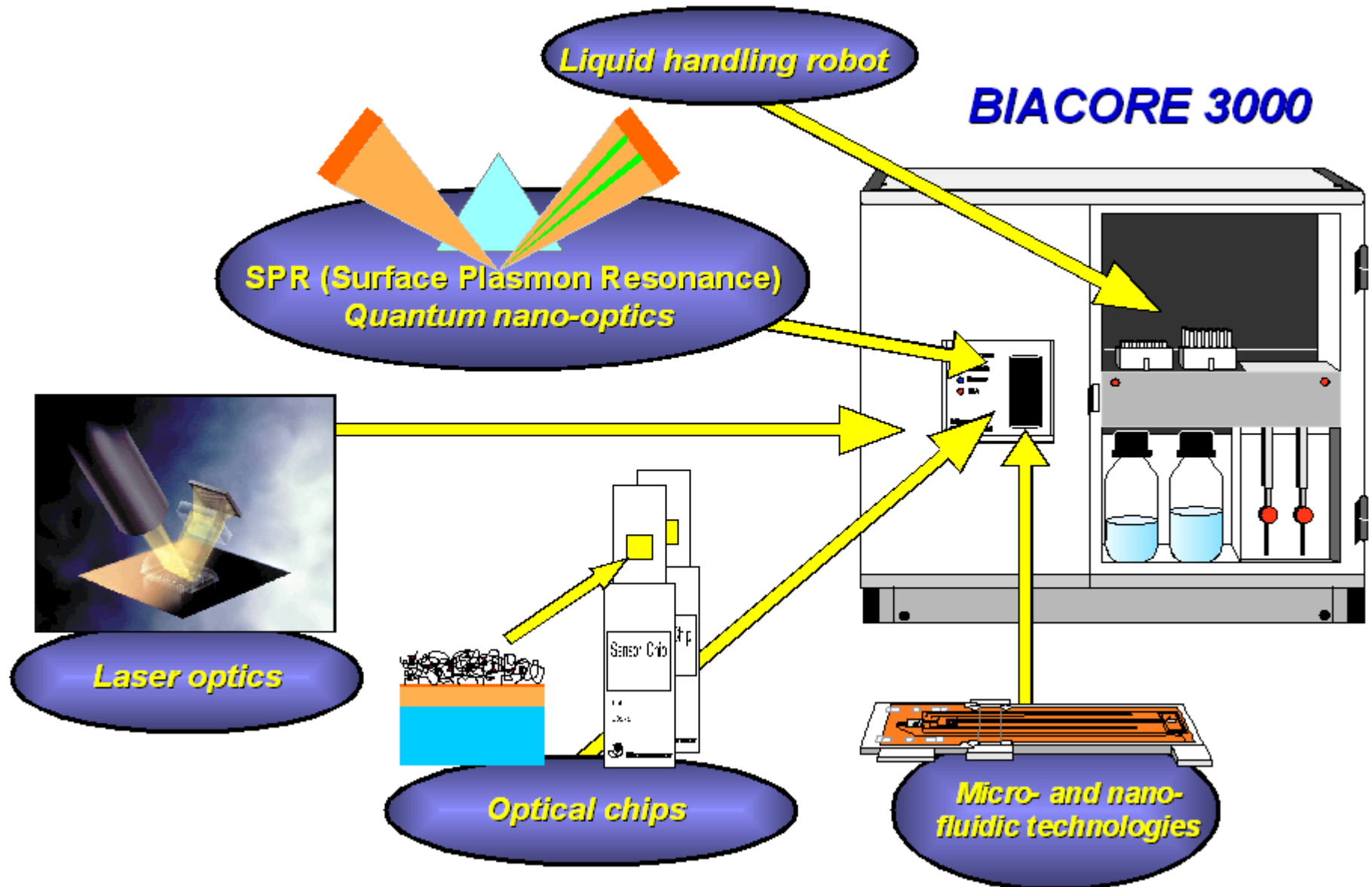
» The equilibrium constant:

$$K_A = \frac{[AB]}{[A] \cdot [B]} = \frac{k_a}{k_d}$$

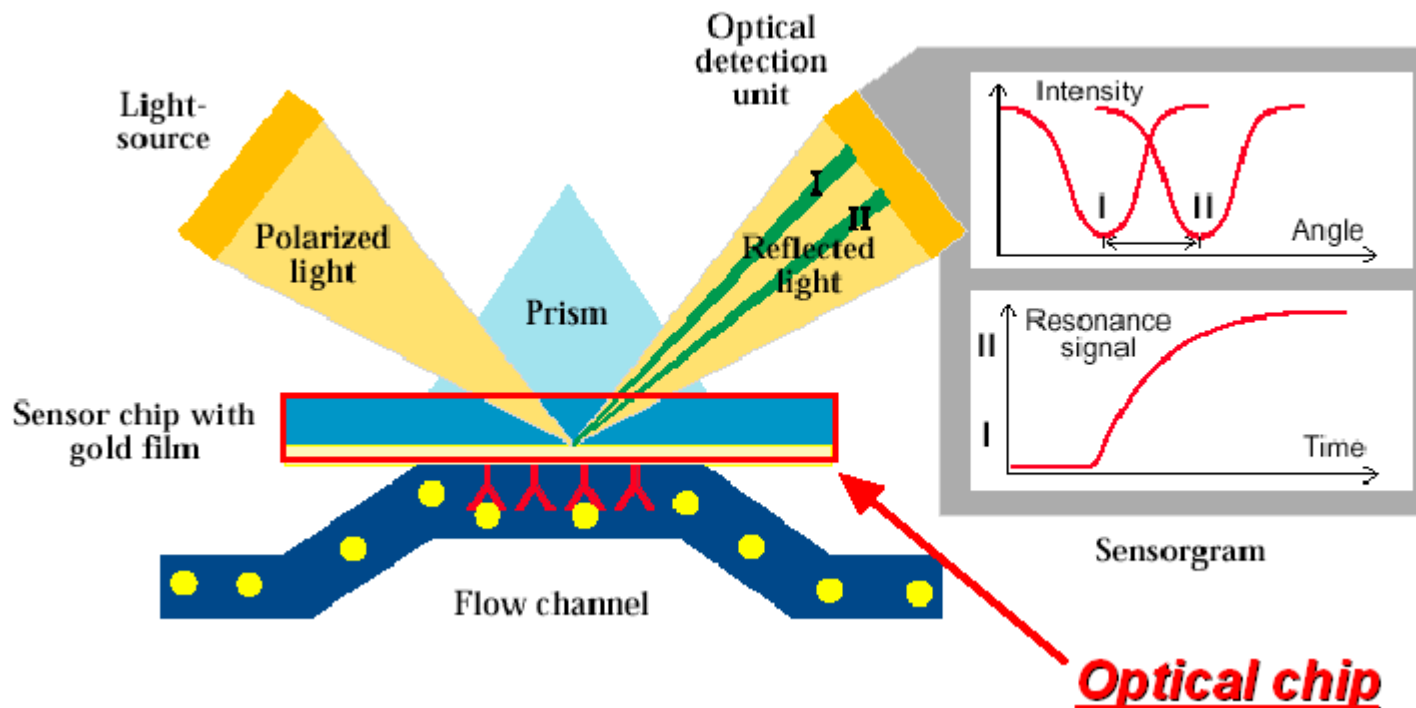
$$K_D = \frac{[A] \cdot [B]}{[AB]} = \frac{k_d}{k_a}$$



# 5 High Technologies in one instrument

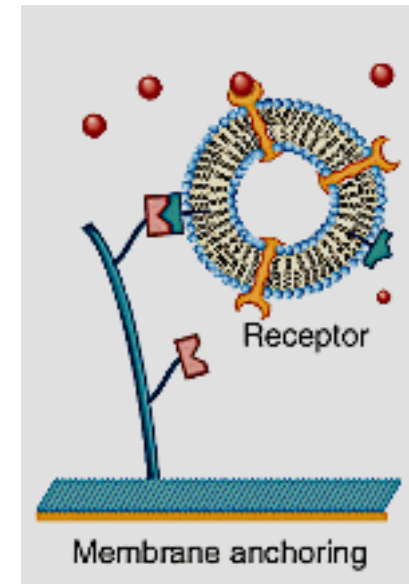
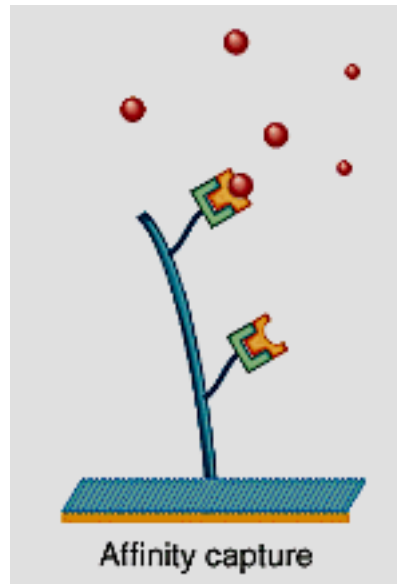
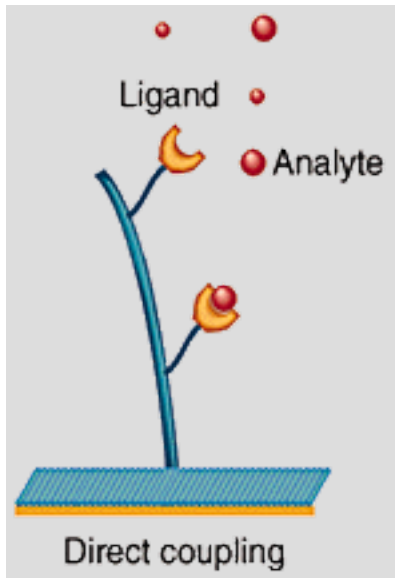


# Plug-in optical module in BIACORE SPR biosensor

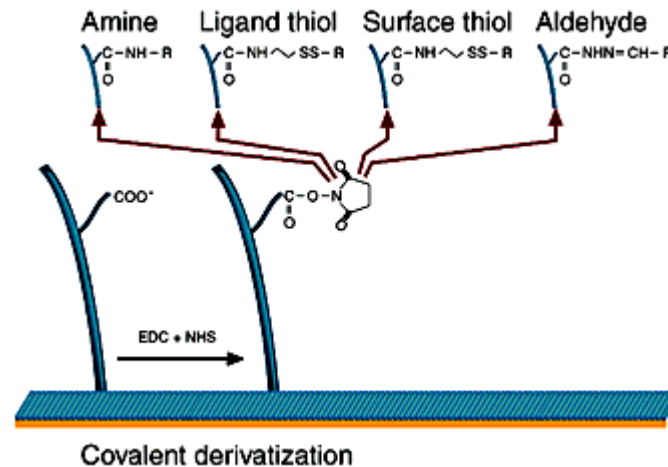


- **Part of optical train**
- **Thin gold film**
- **Different methods of ligand immobilization**

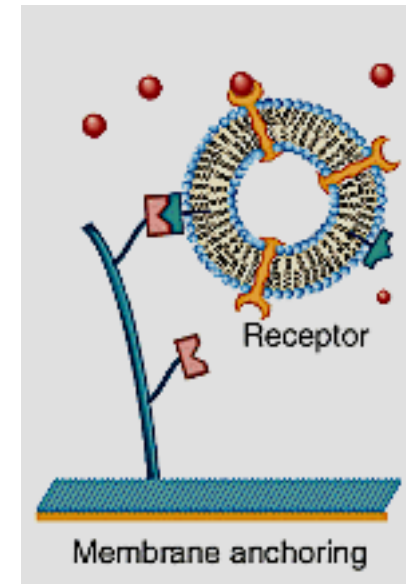
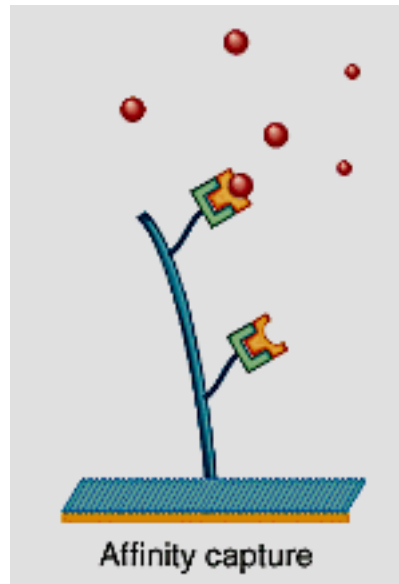
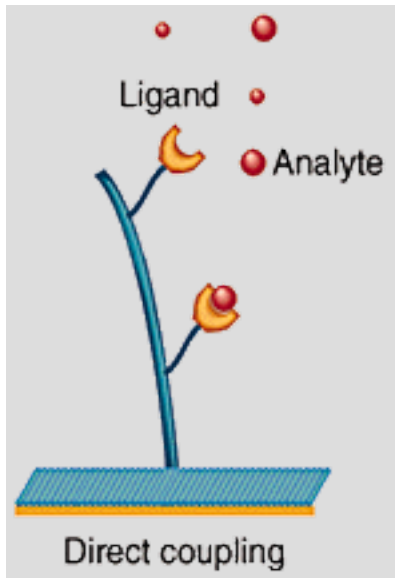
# Ligand immobilization alternatives



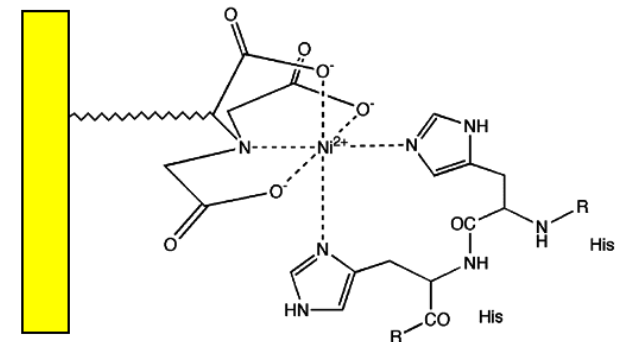
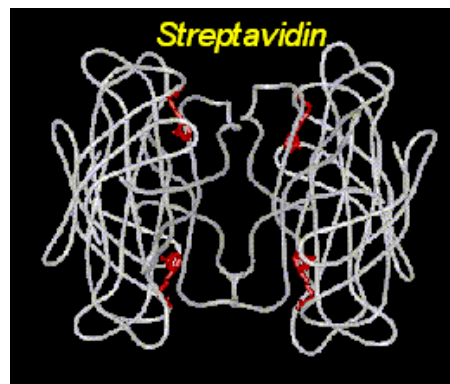
- **Direct chemical immobilization (covalent bounding)**



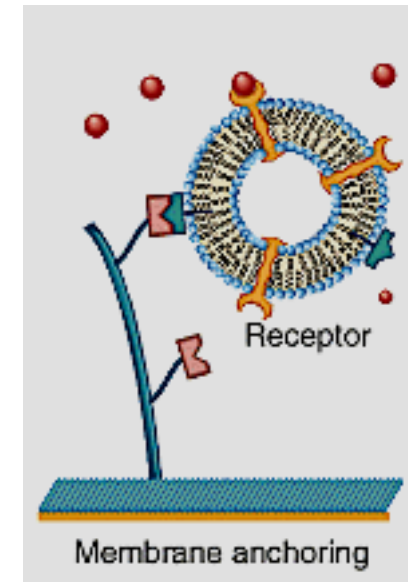
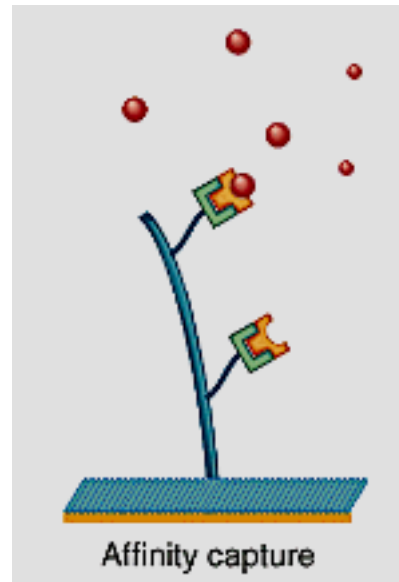
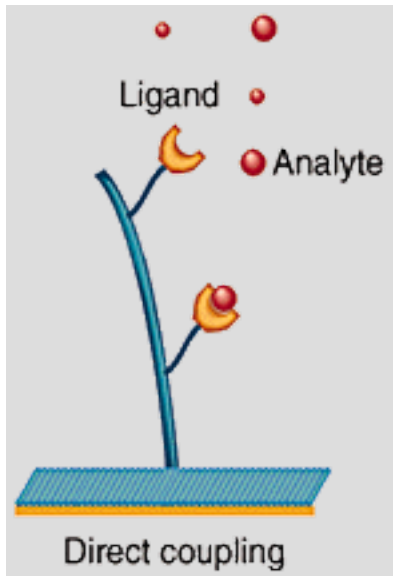
# Ligand immobilization alternatives



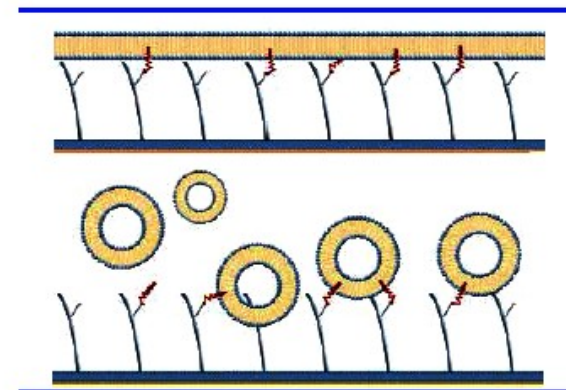
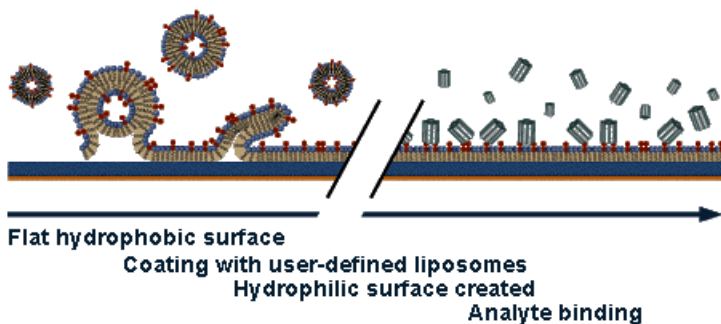
- **Indirect affinity immobilization (chelate complexes, antibody, receptors, biotin/streptavidin, ...)**



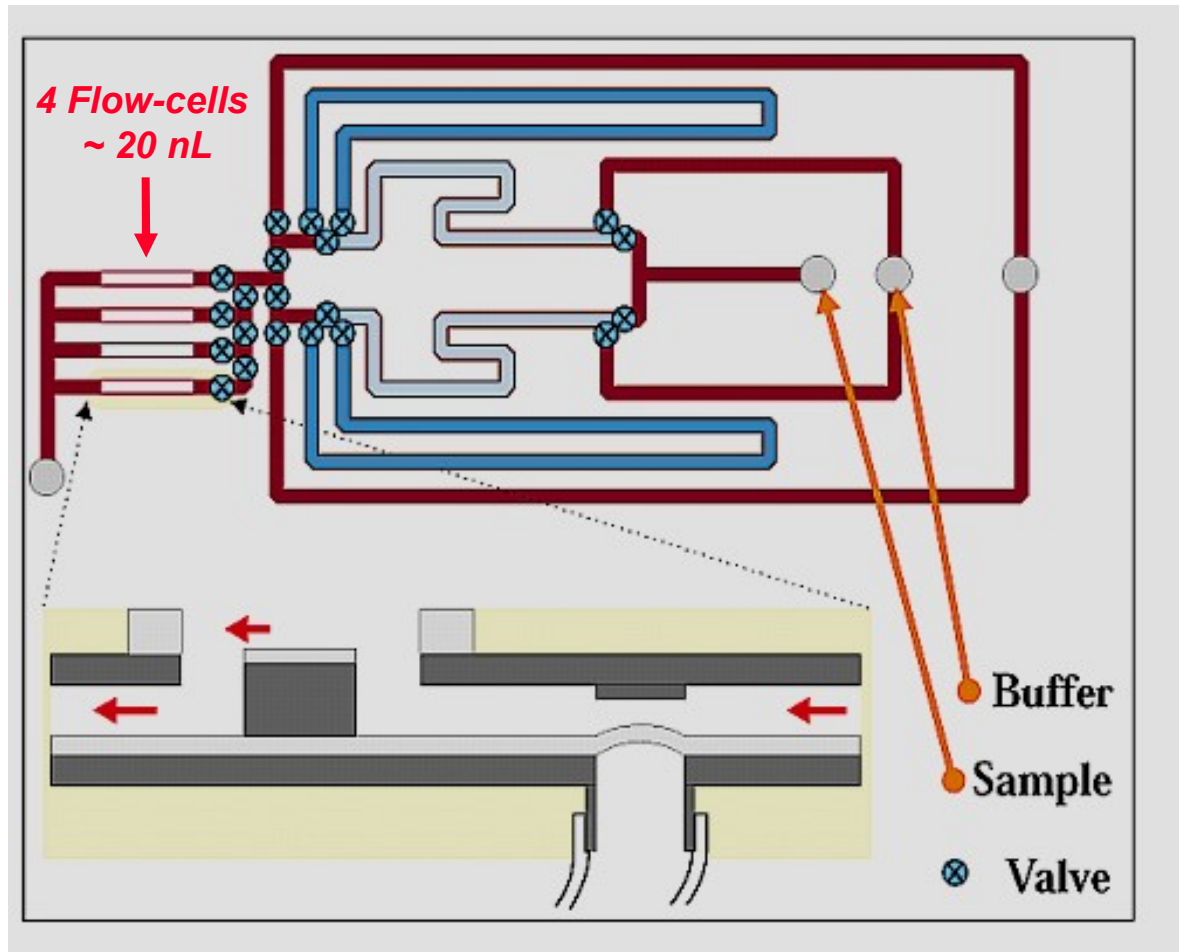
# Ligand immobilization alternatives



- **Membrane systems**  
(lipid monolayer, lipid bilayer, liposomes, micelles, ...)

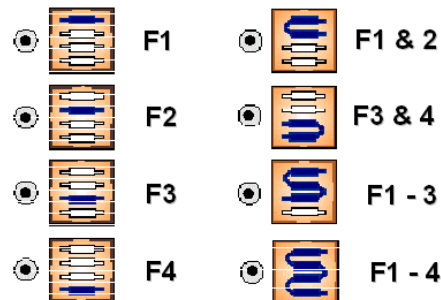


# Micro-fluidic device

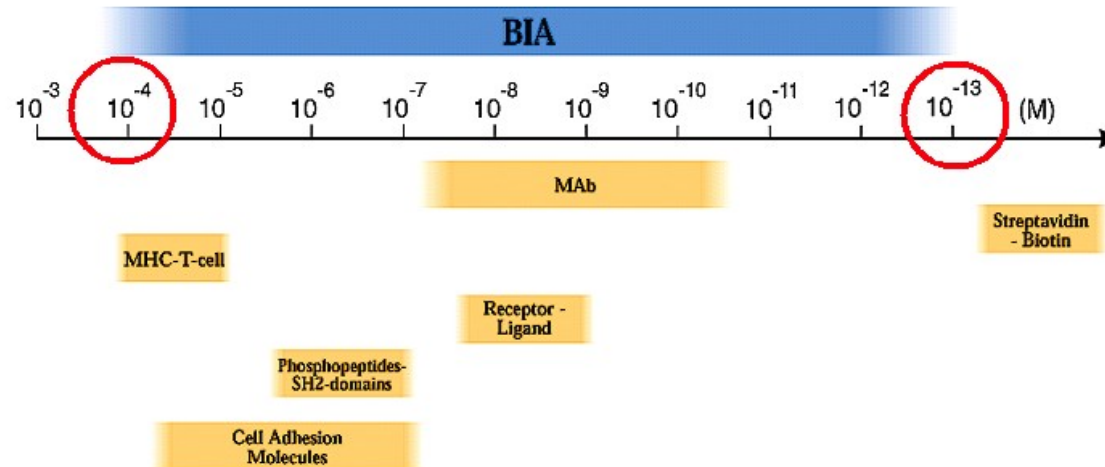


## BIACORE

- ➔ *Low chemicals consumption*
- ➔ *Effective mass-transfer*
- ➔ *Low dispersion*
- ➔ *High reproducibility (>99%)*
- ➔ *Broad time period of registration (from 1 s upto 12 hours)*
- ➔ *Sample collection and fractionation*
- ➔ *4 Flow nano-cells (~ 20 nL x 4)*
- ➔ *Pneumatic micro-valves*
- ➔ *Flexible flow-cells commutation*



# Main properties of SPR biosensors



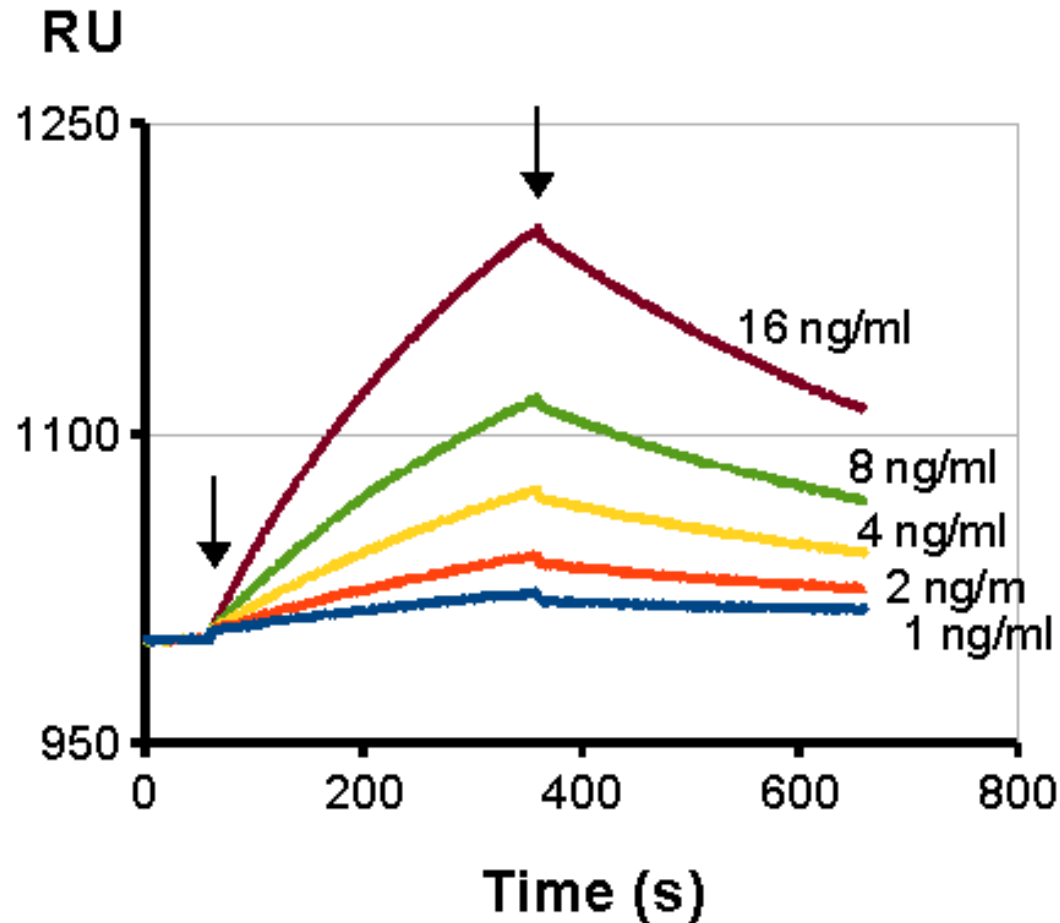
- **Quantitative analysis in broad measurement range**
- **High sensitivity (1 pictogram =  $10^{-12}$  g of protein)**
- **Sense low molecular weight analyte compounds ( $\geq 100$  Da)**
- **Real time**
- **Kinetic and steady state data**
- **Direct measurement (without labels, coupled reactions, ...)**
- **High universality (any compounds, any interactions)**
- **High automation (up to 400 samples per day)**

---

***Some examples of SPR analysis in  
Laboratory of molecular interactions  
of IBMCh RAMS***

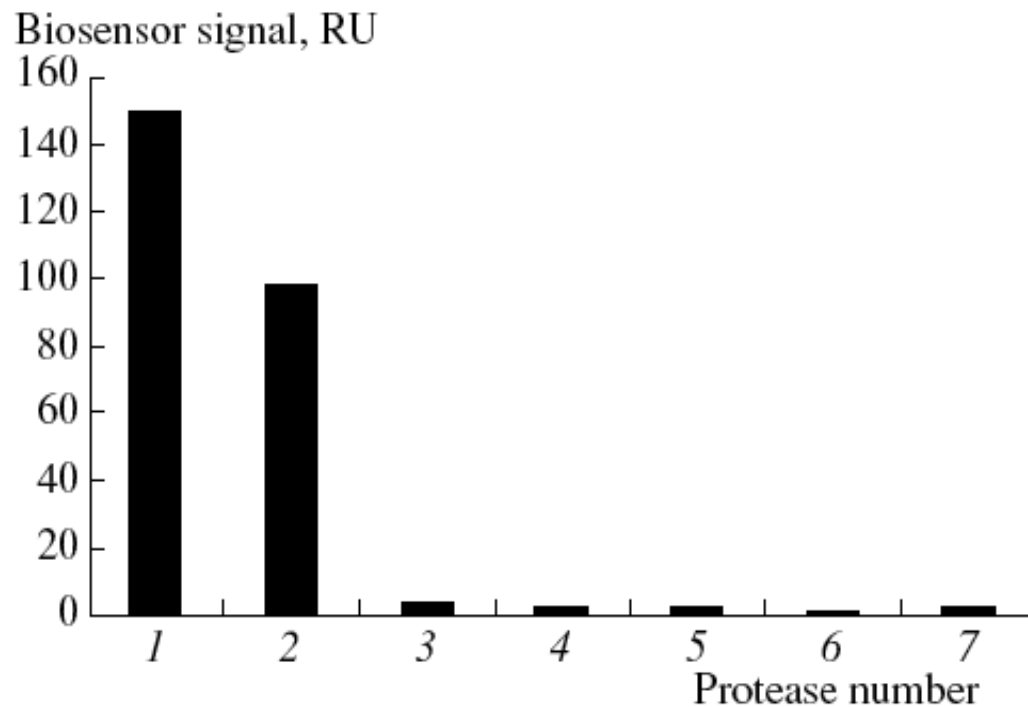


**Example of SPR analysis of molecular interactions:  
MAb (immobilized) - Myoglobin in blood serum**

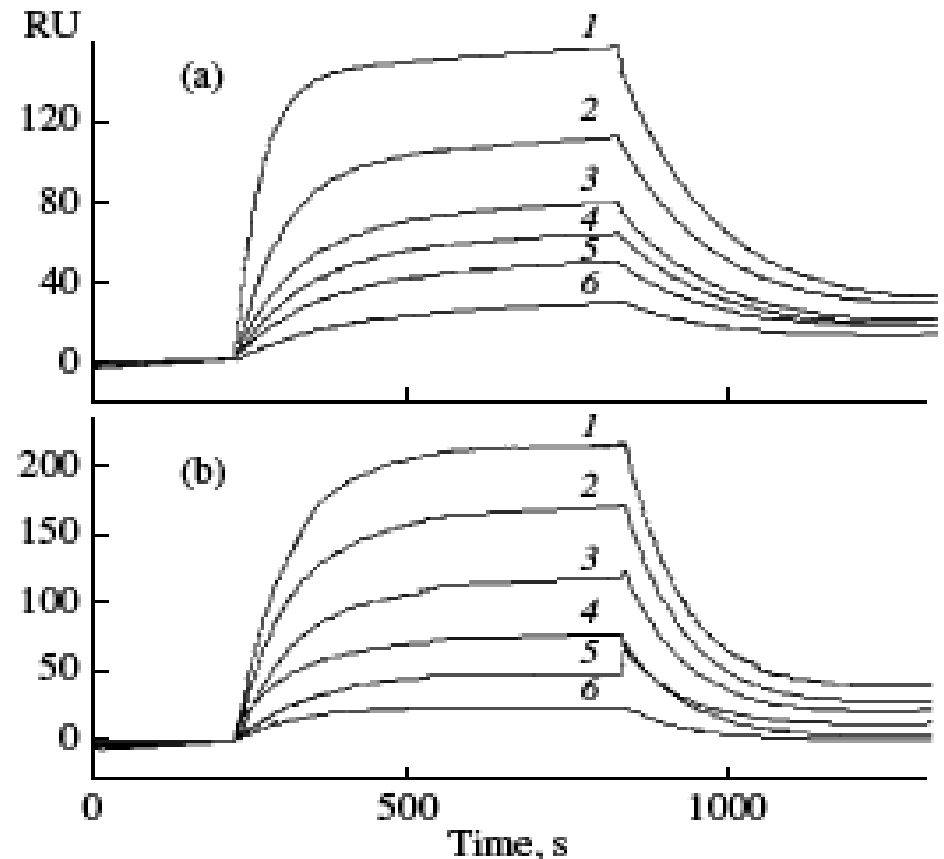


**MAb (immobilized) - Myoglobin in blood serum**

## Example of SPR analysis of molecular interactions: Trypsin inhibitor from Sea Anemone (immobilized) - Proteases

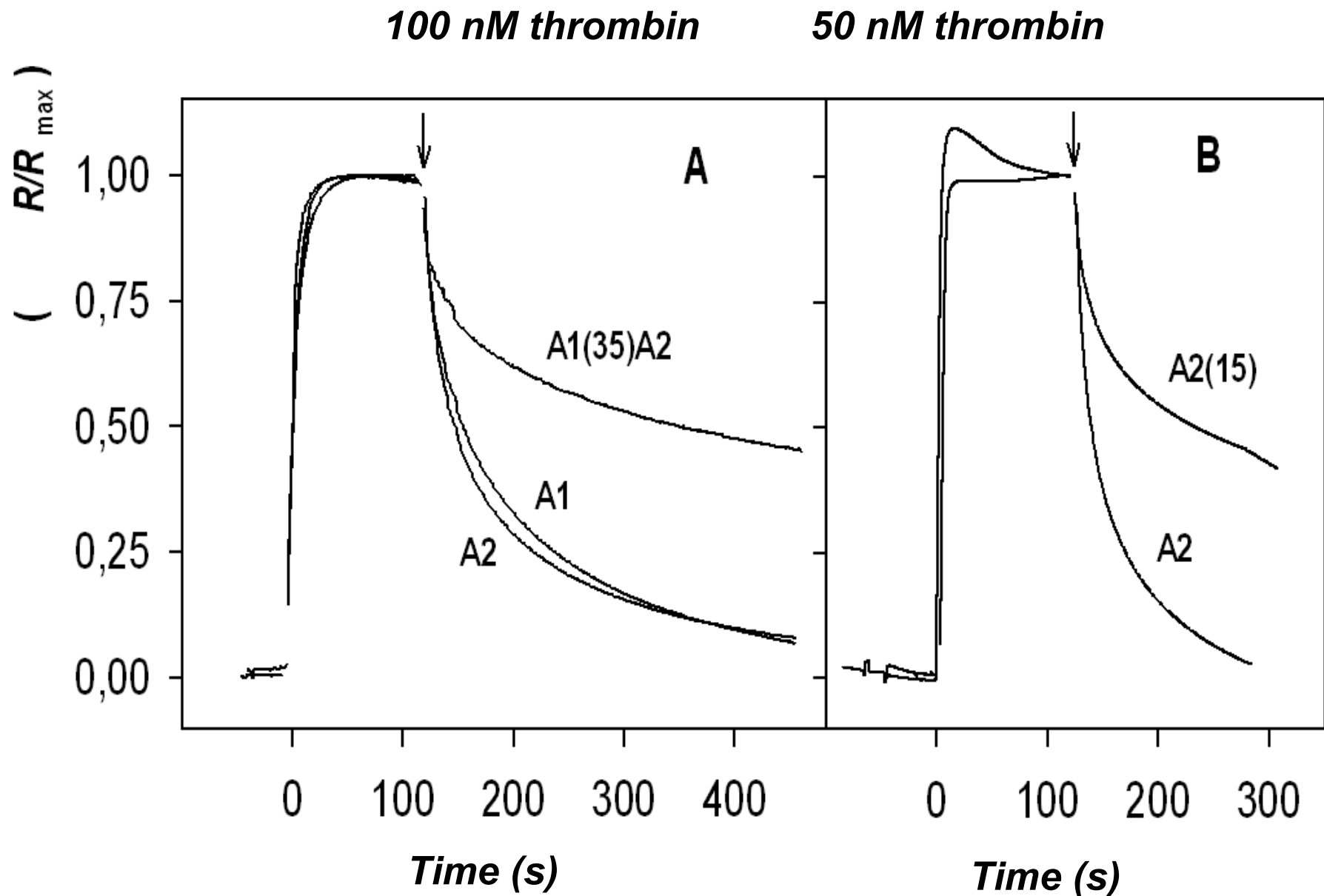


**Fig. 2.** The sensograms of interaction of the proteolytic enzymes with the immobilized inhibitor InhVJ: (1) trypsin; (2)  $\alpha$ -chymotrypsin; (3) kallikrein; (4) plasmin; (5) thrombin; (6) papain; (7) pepsin. Measurements were carried out at 25°C; protease concentration was 200 nM.



**Fig. 3.** The sensograms of interaction of the proteolytic enzymes with the immobilized inhibitor InhVJ<sub>imm</sub>. (a) Interaction of InhVJ<sub>imm</sub> with Tr (10–200 nM): (1) 200 nM; (2) 90 nM; (3) 40 nM; (4) 30 nM; (5) 20 nM; (6) 10 nM. (b) Interaction of InhVJ<sub>imm</sub> with ChTr (40–400 nM): (1) 400 nM; (2) 300 nM; (3) 200 nM; (4) 120 nM; (5) 90 nM; (6) 40 nM. Measurements were carried out at 25°C.

**Example of SPR analysis of molecular interactions:  
DNA aptamers (immobilized) - Thrombin**



## Example of SPR analysis of molecular interactions: Anionic phospholipids (in immobilized bilayer) - cytochrome c

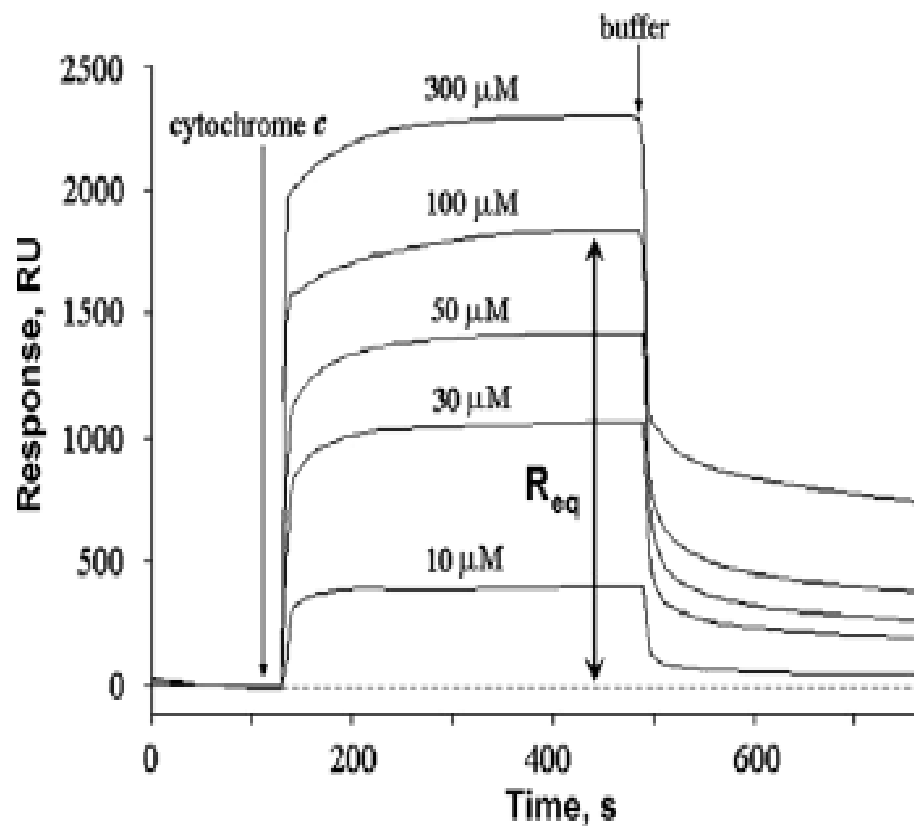


Fig. 2. Sensorgrams of cytochrome c binding to TOCL. Representative sensorgram of L1 immobilized TOCL titration by increasing concentrations of cytochrome c. The specific binding profiles of the cytochrome c to the immobilized TOCL were obtained after subtracting the control flow cell with immobilized PSPC signal from the TOCL response signal.

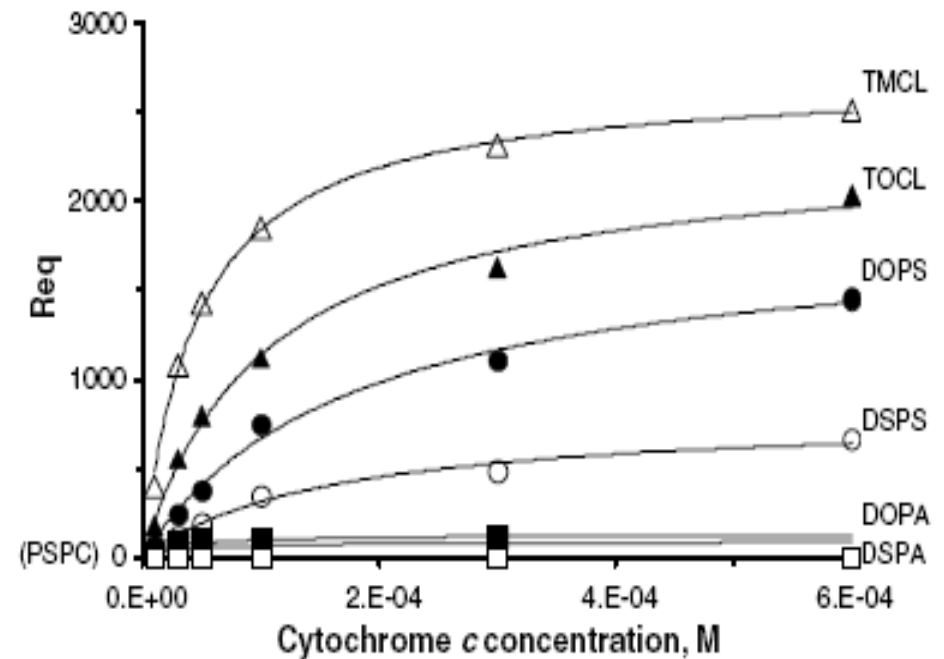
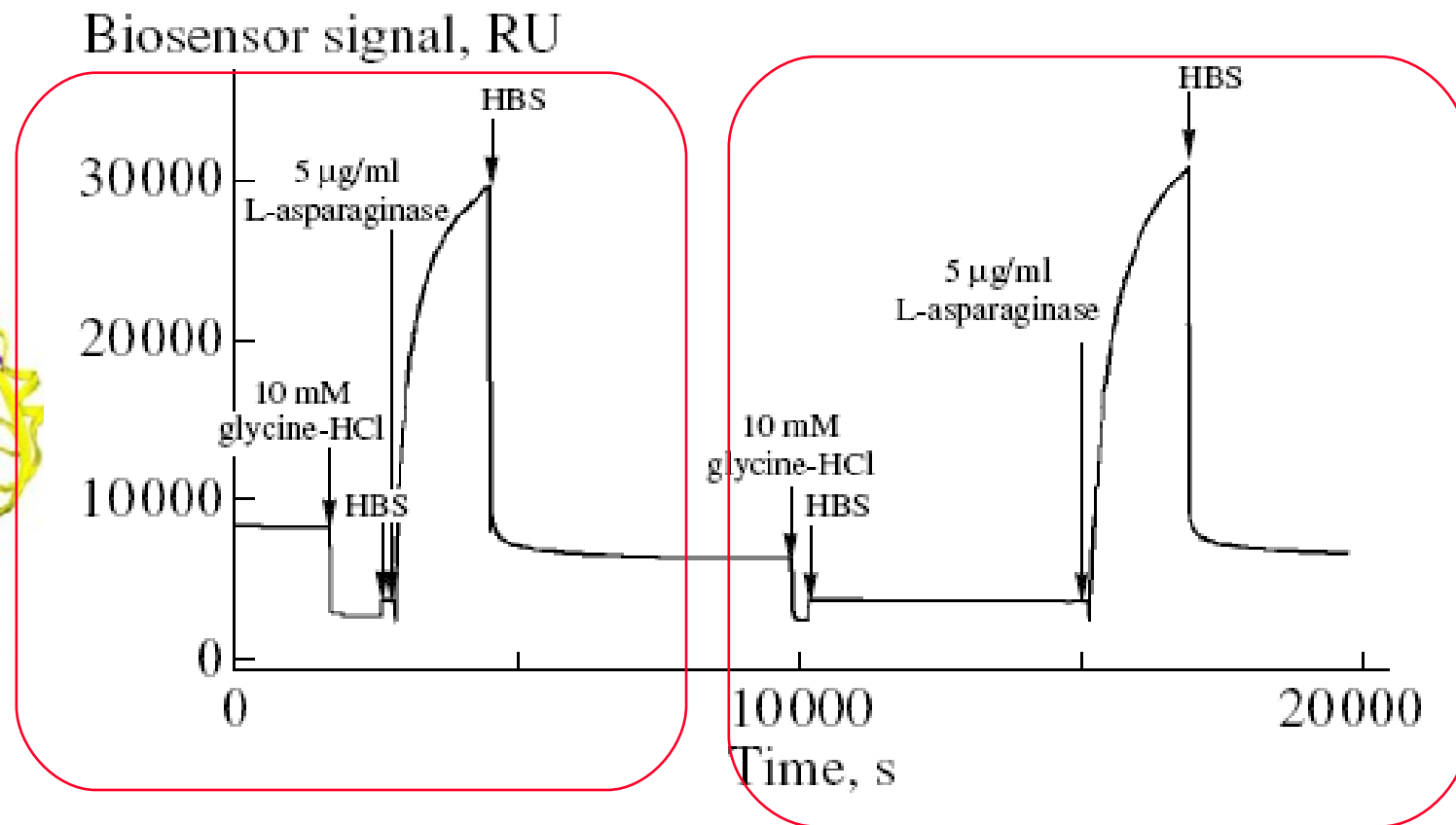
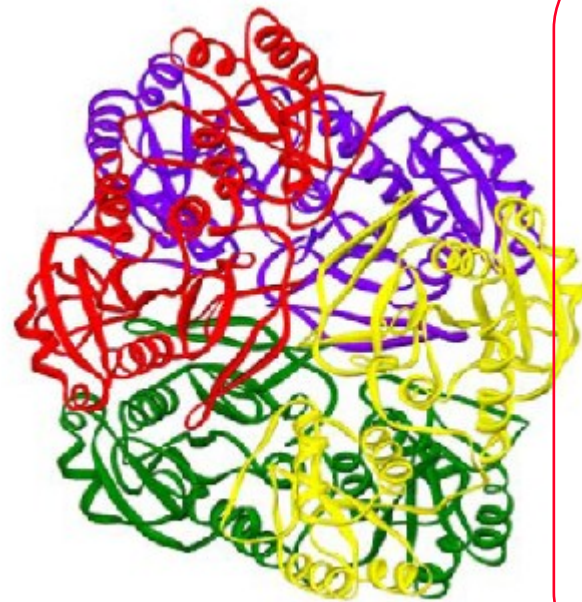


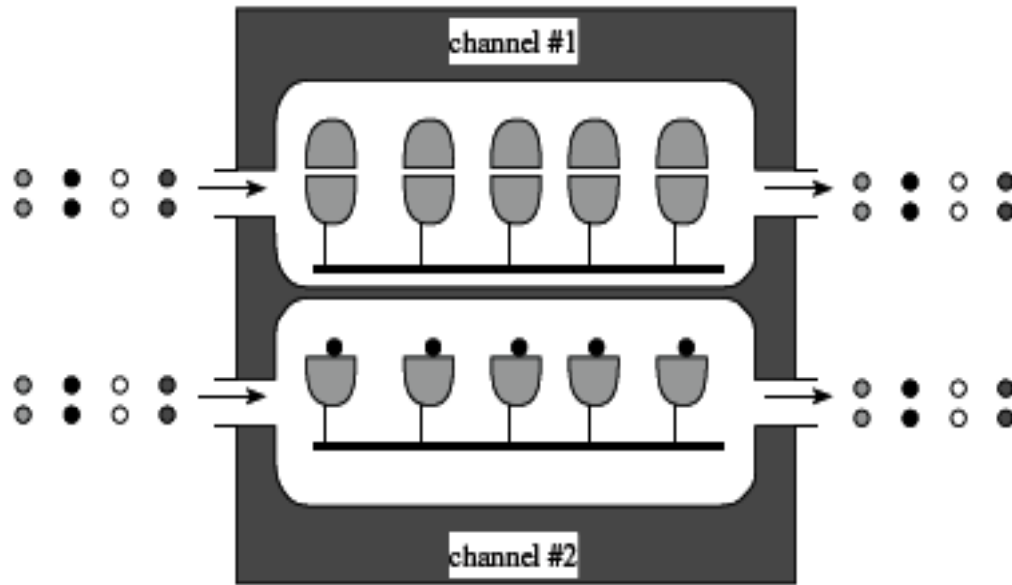
Fig. 3. Effect of cytochrome c on the SPR signal intensity ( $R_{eq}$ ) in various phospholipids. Each point represents the difference of cytochrome c association ( $R_{eq}$ ) between the reference channel (PSPC) and sample channels (TMCL ( $\Delta$ ); TOCL ( $\blacktriangle$ ); DSPS ( $\circ$ ); DOPS ( $\bullet$ ); DSPA ( $\square$ ); DOPA ( $\blacksquare$ )). Cyt c (10  $\mu$ M) in phosphate buffer was used.

# Oligomerization of bacterial L-asparaginase

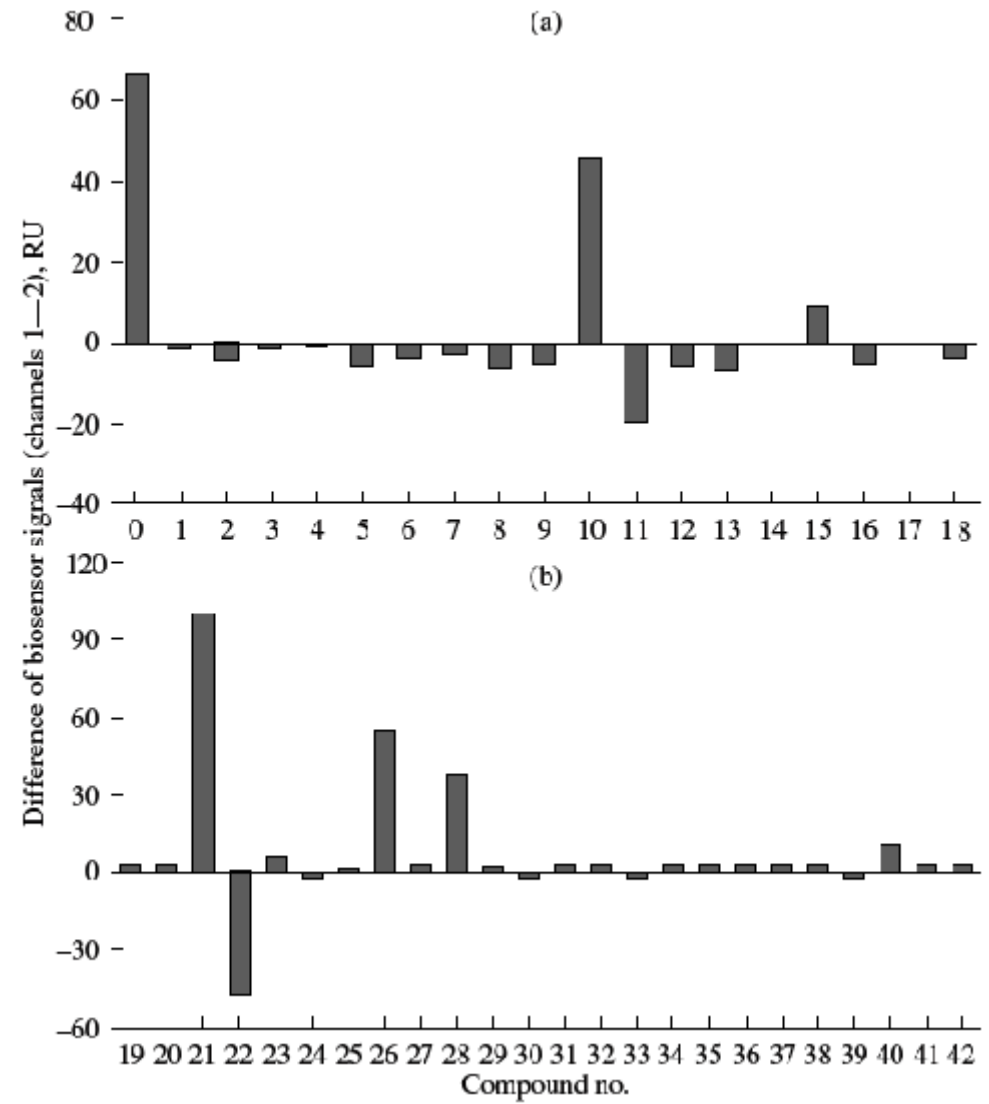


**Fig. 9.** Dissociation of L-asparaginase tetramers to monomers caused by the injection of 10 mM glycine-HCl buffer (pH 2.5) (flow rate of 1 µl/min) and subsequent enzyme oligomerization during flow of L-asparaginase solution in 10 mM acetate buffer (pH 4.5) (flow rate 1 µl/min).

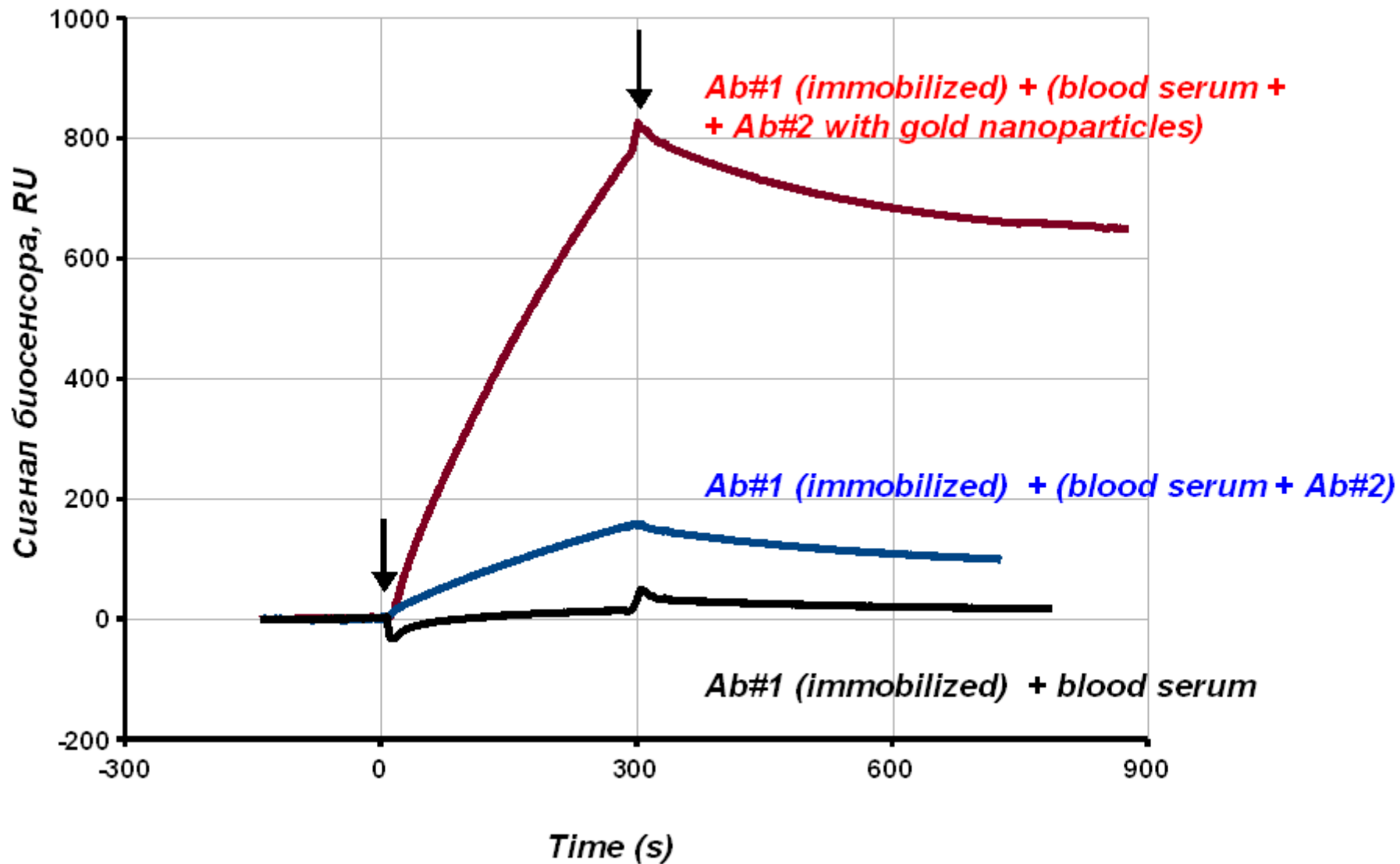
## Example of SPR analysis of molecular interactions: Screening of inhibitors of HIV protease dimerization



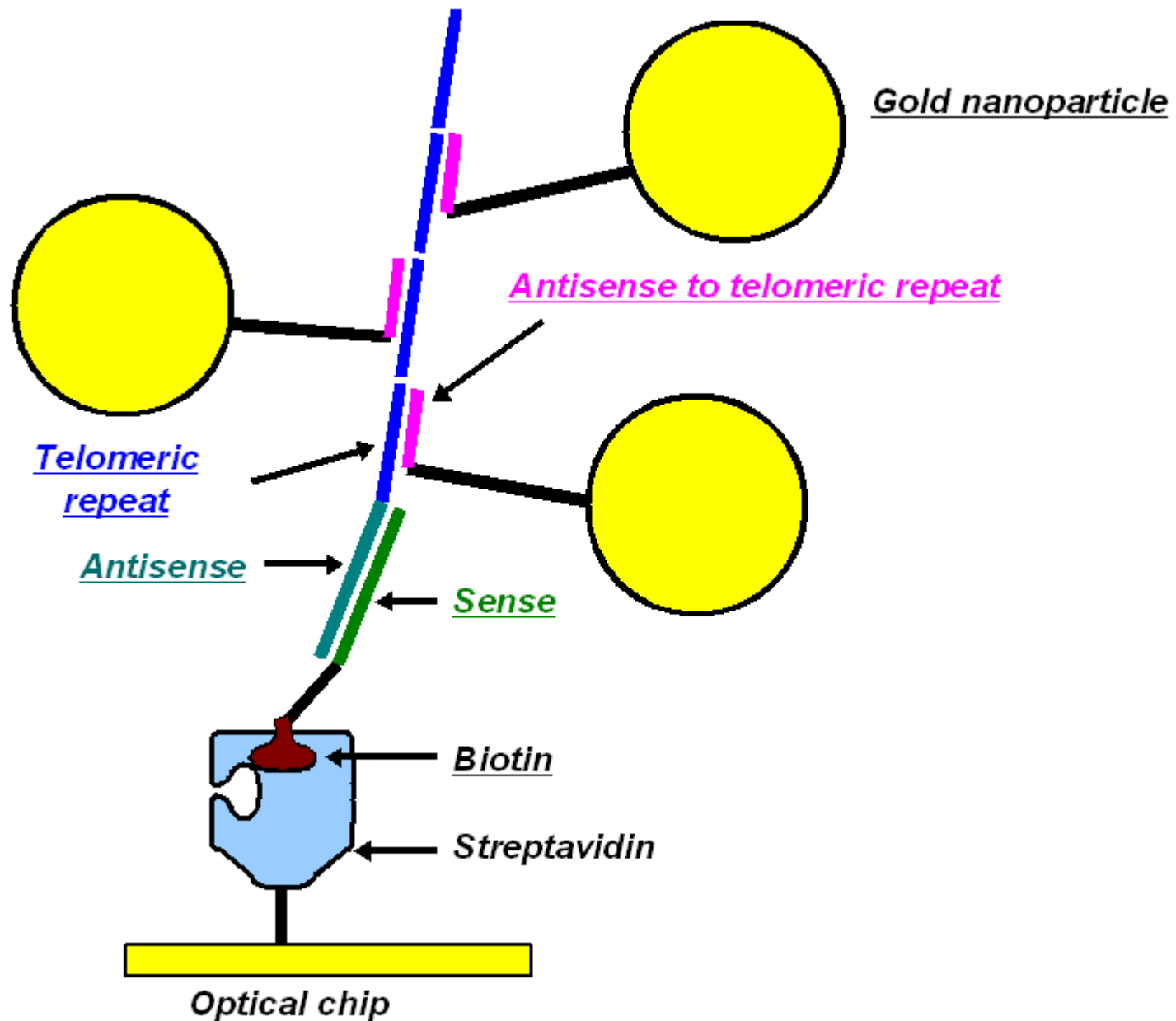
**Fig. 2.** The scheme of the differential biosensor test system for the analysis of interaction of potential dimerization inhibitors with dimers and monomers of HIVp. Channel 1 contains immobilized and stabilized dimeric form of HIVp, channel 2 contains monomeric form of HIVp. The testing is carried out by sequential injections of solutions of analyzed substances (shown as circles of various colors) into both biosensor channels. Binding of a tested compound only with HIVp monomers immobilized in channel 2 (black circles) is considered as a positive result.



# SPR signal amplification by gold nanoparticles

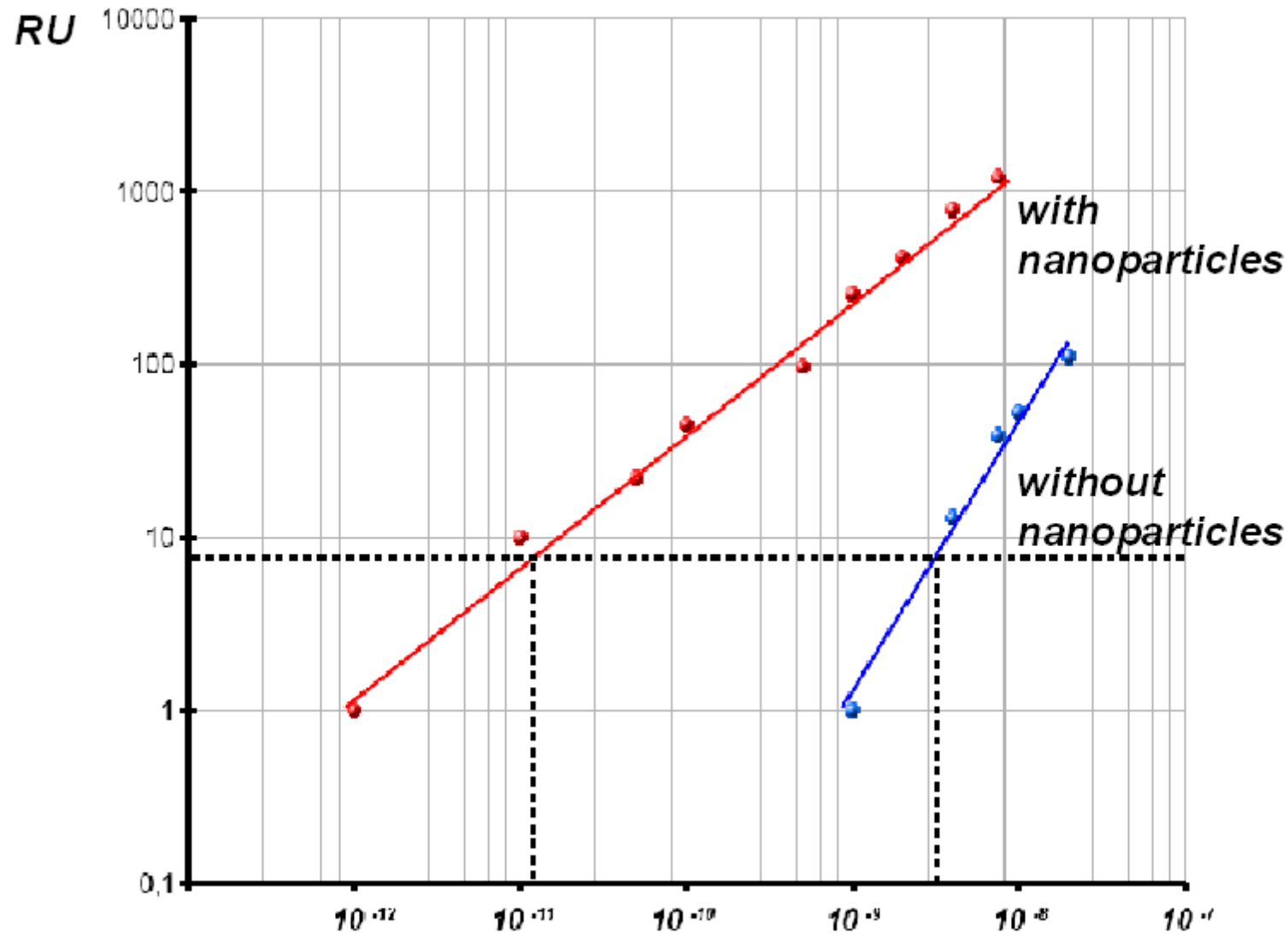


# Telomeric repeats analysis in oligonucleotides



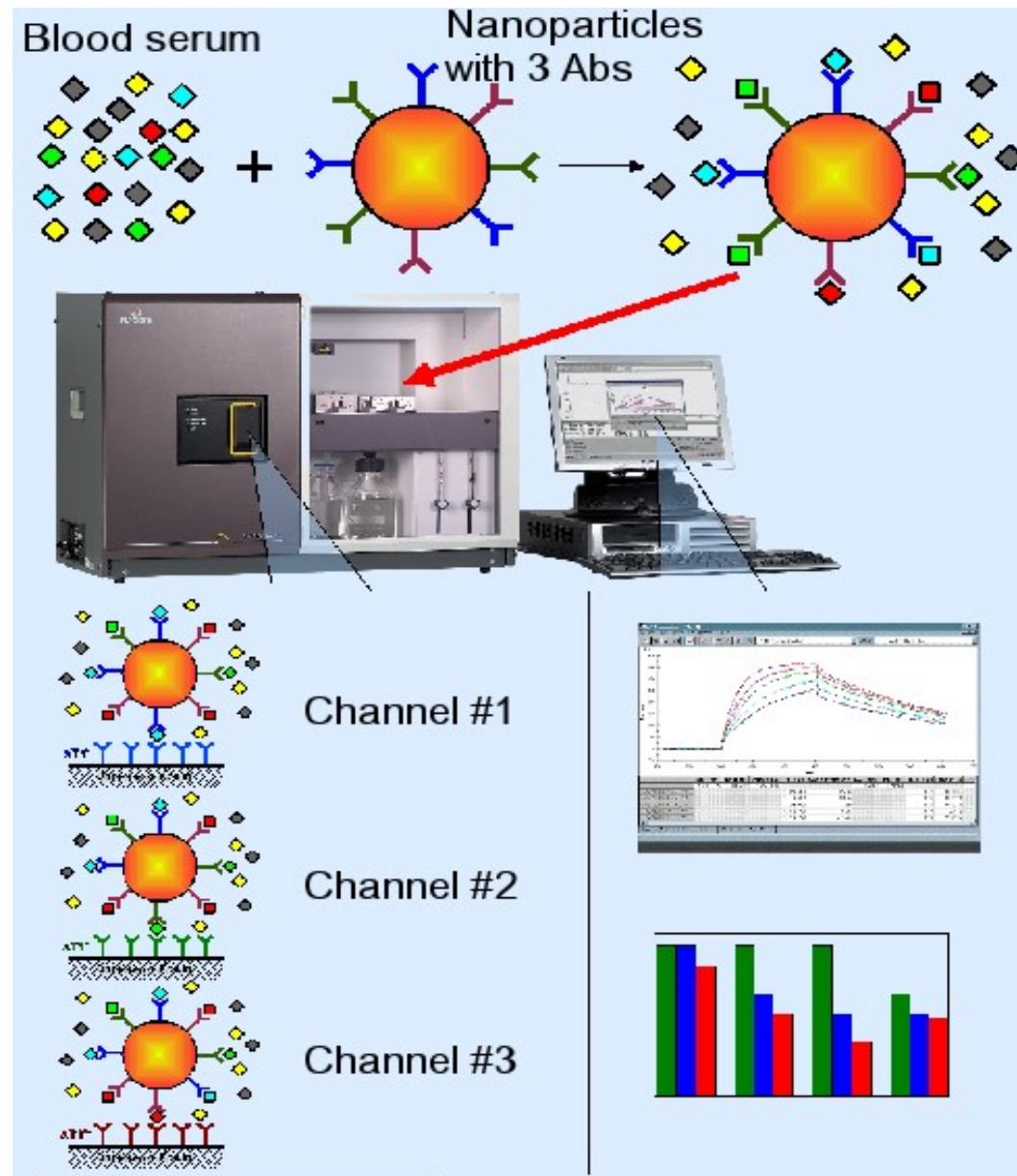


# Direct SPR analysis of acute heart attack biomarkers in blood serum



Myoglobin (cardio) concentration in model blood serum

# Simultaneous measurement 3 acute heart attack biomarkers in blood serum



---

***Thank you for attention***